

# QR-25<sup>®</sup> Series Model 325

Parts Manual  
Record of Change 107

This manual contains important safety information and must be carefully read in its entirety and understood prior to installation by all personnel who install, operate and/or maintain this product.

*On-line product registration, parts ordering and warranty information is available at [www.quincycompressor.com](http://www.quincycompressor.com)*

Manual No. 2022204900

July 2014 Edition



# INTRODUCTION

This manual provides information for the following QR-25 Series, Model 325 (Record of Change 107) compressor versions:

- L Control Version L**  
head assembly with 1 unloader tower & a hydraulic unloader
- LS Control Version LS**  
head assembly with 2 unloader towers, a hydraulic unloader, & a pilot valve with a check valve assembly
- LVD Control Version LVD**  
head assembly with 2 unloader towers, a hydraulic unloader, & a pilot valve with a lockout & check valve

These compressors are aircooled, two stage, two cylinder, pressure lubricated compressors, with up to 200 PSI continuous pressure capability (*201 to 500 PSI intermittent pressure capability with proper configuration; consult factory*). The Model 325 has a 4.5" low pressure piston bore and a 2.5" high pressure piston bore and a 3" stroke and can be run at 400-900 RPM.

- Available options included in this manual:
- high pressure rated cylinder and head
  - hooded air filter
  - hooded air filter / silencer

# CHANGES

*since previous printing dated January 2014:*  
The bearing carrier group was redesigned with a new oil pump including an oil filter

# TABLE OF CONTENTS

<b>Serial Number Identification</b> .....	2
<b>Ordering Replacement Parts</b> .....	2
<b>Quin-Cip Lubricant</b> .....	2
<b>Crankcase Lubricant Capacity</b> .....	2
<b>Crankshaft Group</b> .....	3
<b>Crankcase Group</b> .....	4
<b>Bearing Carrier Group</b> .....	5
<b>Connecting Rod &amp; Piston Groups</b>	
<b>High Pressure</b> .....	6-7
<b>Low Pressure</b> .....	8-9
<b>Cylinder &amp; Head Groups</b>	
<b>Control Version L</b> .....	10-11
<b>Control Versions LS, LVD</b> .....	12-13
<b>Head Assemblies</b>	
<b>Control Version L</b> .....	14-15
<b>Control Versions LS, LVD</b> .....	16-17
<b>Control Groups</b>	
<b>Version L</b> .....	18
<b>Version LS</b> .....	19
<b>Version LVD</b> .....	20
<b>Pilot Valves</b> .....	21
<b>Differential Setting Charts</b> .....	21
<b>Suction Valve Unloader Assemblies</b> .....	22
<b>Gasket Set</b> .....	23
<b>Kits</b> .....	23
<b>Recommended Spare Parts</b> .....	24
<b>Decals</b> .....	24
<b>Typical Unit Repair Parts List</b> .....	25-27

# MODEL & SERIAL NUMBER IDENTIFICATION

Record of Change No.

<b>MODEL</b>		
<b>SERIAL NO.</b>		
110831		

**Model & Serial Number Identification Tag**

The model & serial number tag is located on the handhole plate side of the crankcase. Fill in the numbers from your compressor's tag in the corresponding spaces provided here and reference this page when ordering replacement parts.

All replacement parts are to be ordered through an authorized Quincy distributor. Insist on genuine Quincy parts only! Failure to do so may void warranty.

# QUIN-CIP LUBRICANT

Refer to the chart below to order Quin-Cip-D or Quin-Cip compressor lubricant from your local authorized Quincy distributor.

<b>Quin-Cip-D Lubricant (synthetic)</b>	
<b>SAE 30 (ISO 100)</b>	
Quart	115468Q
Case (12 Qts.)	115438C
<b>Quin-Cip Lubricant</b>	
<b>SAE 10W (ISO 32)</b>	
Quart	112541Q032
Case (12 Qts.)	112541C032
<b>SAE 20 (ISO 68)</b>	
Quart	112542Q068
Case (12 Qts.)	112542C068
<b>SAE 30 (ISO 100)</b>	
Quart	112543Q100
Case (12 Qts.)	112543C100

# ORDERING REPLACEMENT PARTS

Prompt service can be rendered on repair parts orders if the following information is given:

- Item 1)** the model number, record of change number, & serial number.
- Item 2)** the exact part number needed. (Do not order by item numbers.)
- Item 3)** the exact quantity needed.
- Item 4)** the preferred type of transportation

# CRANKCASE LUBRICANT CAPACITY

<b>Model</b>	<b>Capacity</b>
325	1 qt. & 22 oz. (1.596 lit.)

**CAUTION !**  
Refer to the Quincy QR-25 Series instruction manual for vital lubrication information.

**CAUTION !**  
Follow all safety precautions outlined in the QR-25 Series instruction manual.

**WARNING !**  
Do not operate this compressor without a totally enclosed belt guard or any other required safety equipment.

**DANGER !**  
Air used for breathing or food processing must meet OSHA 1910.134 or FDA 21 CFR 178.3570 regulations. Failure to do so may cause severe injury or death.

# CRANKSHAFT GROUP 110238

Item Number	Qty.	Part Number	Description
1	1	110217	crankshaft assembly
1.1	1	110216	crankshaft (N.S.S.; order 110217)
1.2	1	110234	orifice, 1/8 npt
1.3	2	2755S	pipe plug, 1/8 npt
1.4	1	2585	bearing cone
1.5	1	2788	bearing cone
1.6	1	110705-F15	pin
2	1	1466	key
3	1	110472X	sheave assembly
3.1	1	4126R	sheave, 16", 2 groove, B sect., ccw (N.S.S.; order 110472X)
3.2	2	110983-N23	hex. screw, 1/2-13 unc x 3.50, grade 8 (@ 90 ft.-lbs.)
3.3	2	116124-N02	square nut, 1/2-13 unc
3.4	2	110428N050	flatwasher

N.S.S. = Not Sold Separate

@ Indicates torque value in foot pounds (dry threads)

Note: For reversal of compressor rotation refer to QR-25 instruction manual.

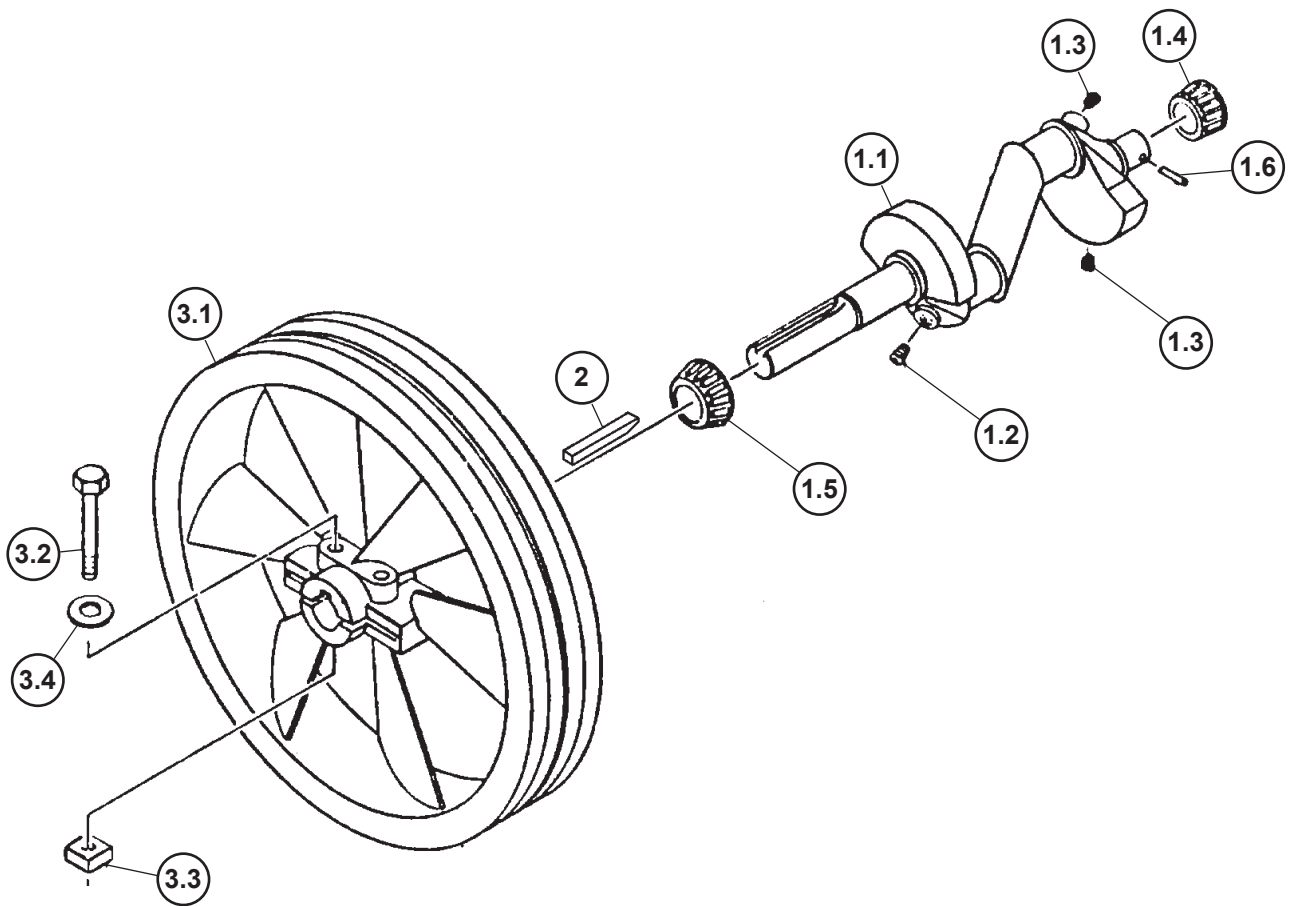

# CRANKCASE GROUP 2021021301

Item Number	Qty.	Part Number	Description
1	1	5503X003	crankcase assembly
1.1	1	5503-003	crankcase
1.2	1	2720	bearing cup
2	*	6294D	bearing adj. shim, .002 steel
3	*	6294	bearing adj. shim, .005 steel
4	*	6294A	bearing adj. shim, .007 steel
5	*	6294B	bearing adj. shim, .020 steel
6	*	6294C	bearing adj. shim, .005 paper
7	4	123478-L10	hex. screw, 3/8-16 unc x .75, grade 5 (@ 30 ft.-lbs.)
8	1	5506X1	bearing adjustment plate assembly
8.1	1	5506	adjustment plate
8.2	1	6316	oil seal
9	1	112031X001	breather assembly
9.1	1	112032-001	breather tube
9.2	1	5783-002	breather ball
9.3	1	110705-C11	roll pin, 3/32 x .81
9.4	1	112031-001	breather body
10	3 ft.	110515-031	copper tube, 5/16 o.d.
11	1	1301	pipe plug, 3/8 npt
12	1	1840	gasket, inspection plate
13	1	2322-1	inspection plate, oil filler type
14	6	123478-K12	hex. screw, 5/16-18 unc x 1.00, grade 5 (@ 12 ft.-lbs.)
15	1	110070-3	oil gauge
16	1	123157-112	"o"ring, 3/32 wide x .69 o.d.
17	1	110919-010	tube fitting, 5/16 tube x 3/8 npt, 90°

## Maintenance Parts

8.2 1 6316 oil seal

Parts for use with diester or phosphate ester synthetic based lubricants

16 1 22749-112 "o"ring, 3/32 wide x .69 o.d.

\* Quantity as required

@ Indicates torque value (dry threads).

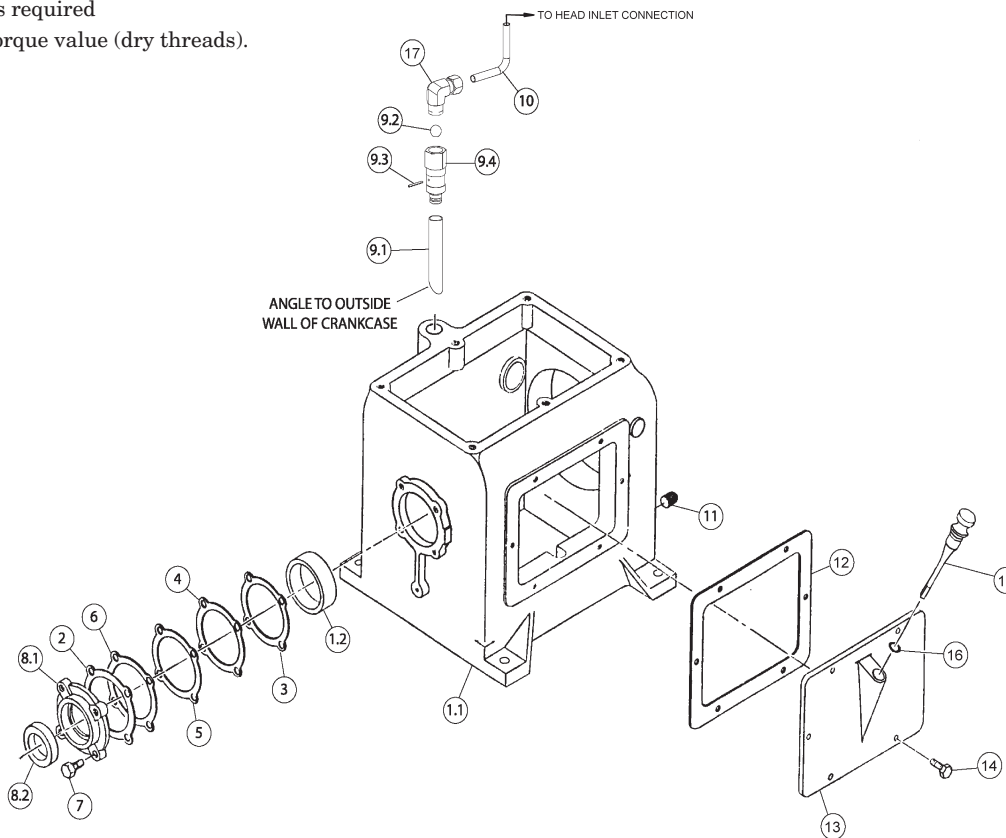

# BEARING CARRIER GROUP 2024400060

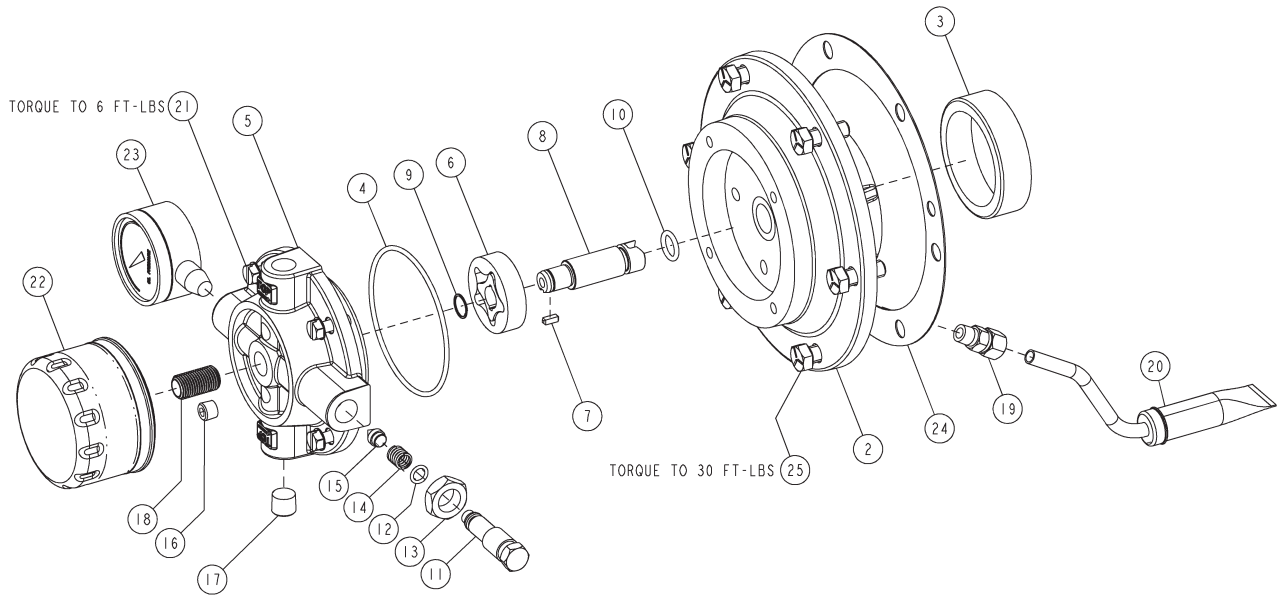

2024400060 BEARING CARRIER GROUP			
ITEM	PART NUMBER	QTY	DESCRIPTION
1	2024400050	1	BEARING CARRIER ASSEMBLY (N.S.S. - ORDER KIT)
2	2024400001	1	BEARING CARRIER
3	2523	1	BEARING CUP
4	22749-152	1	O-RING, VITON
5	2024400601	1	OIL PUMP HOUSING
6	160003	1	OIL PUMP
7	160075-001	1	KEY
8	2024200202	1	OIL PUMP DRIVESHAFT
9	6285	1	RETAINING RING
10	22749-112	1	O-RING, VITON
11	5489	1	ADJUSTMENT SCREW
12	22749-011	1	O-RING, VITON
13	124369-P02	1	JAM NUT
14	1160	1	SPRING
15	112857	1	NEEDLE VALVE
16	2755S	1	PIPE PLUG, 1/8 NPT
* 17	2719	1	PIPE PLUG, 1/4 NPT
** 18	2023400200	1	FILTER STUD
*** 19	2023200108	1	TUBE FITTING,CONNECTOR, 5/16 TUBE X 1/8 NPT
20	2023400002	1	OIL PICKUP TUBE WITH SCREEN
21	123777-J10	4	MACHINE SCREW
22	2023400100	1	OIL FILTER
* 23	110822	1	OIL PRESSURE GAUGE
24	6312	1	BEARING CARRIER GASKET
25	142578-L12	6	CAP SCREW, 3/8-16x1.00, GRADE 5
<b>MAINTENANCE PARTS</b>			
	2023400101		10 PACK OF OIL FILTERS
<b>REPLACEMENT KITS</b>			
	2024400080		BEARING CARRIER ASSEMBLY REPLACEMENT KIT INCLUDES BEARING CARRIER ASSEMBLY, FILTER, GAUGE, AND GASKET

\* INSTALL WITH PIPE SEALANT  
 \*\* INSTALL WITH RETAINING COMPOUND  
 \*\*\* INSTALL WITH PIPE SEALANT ON NPT & THREADLOCKER ON NUT  
 N.S.S. = NOT SOLD SEPARATE  
 TORQUE VALUES ARE FOR DRY THREADS. TIGHTEN MULTIPLE BOLTS, CAPSCREWS, AND HEX NUTS IN A CRISS-CROSS PATTERN. BRING EACH FASTENER TO THE RECOMMENDED TORQUE SPECIFICATION IN EVEN INCREMENTS.

# CONNECTING ROD & PISTON GROUP 110248

(high pressure)

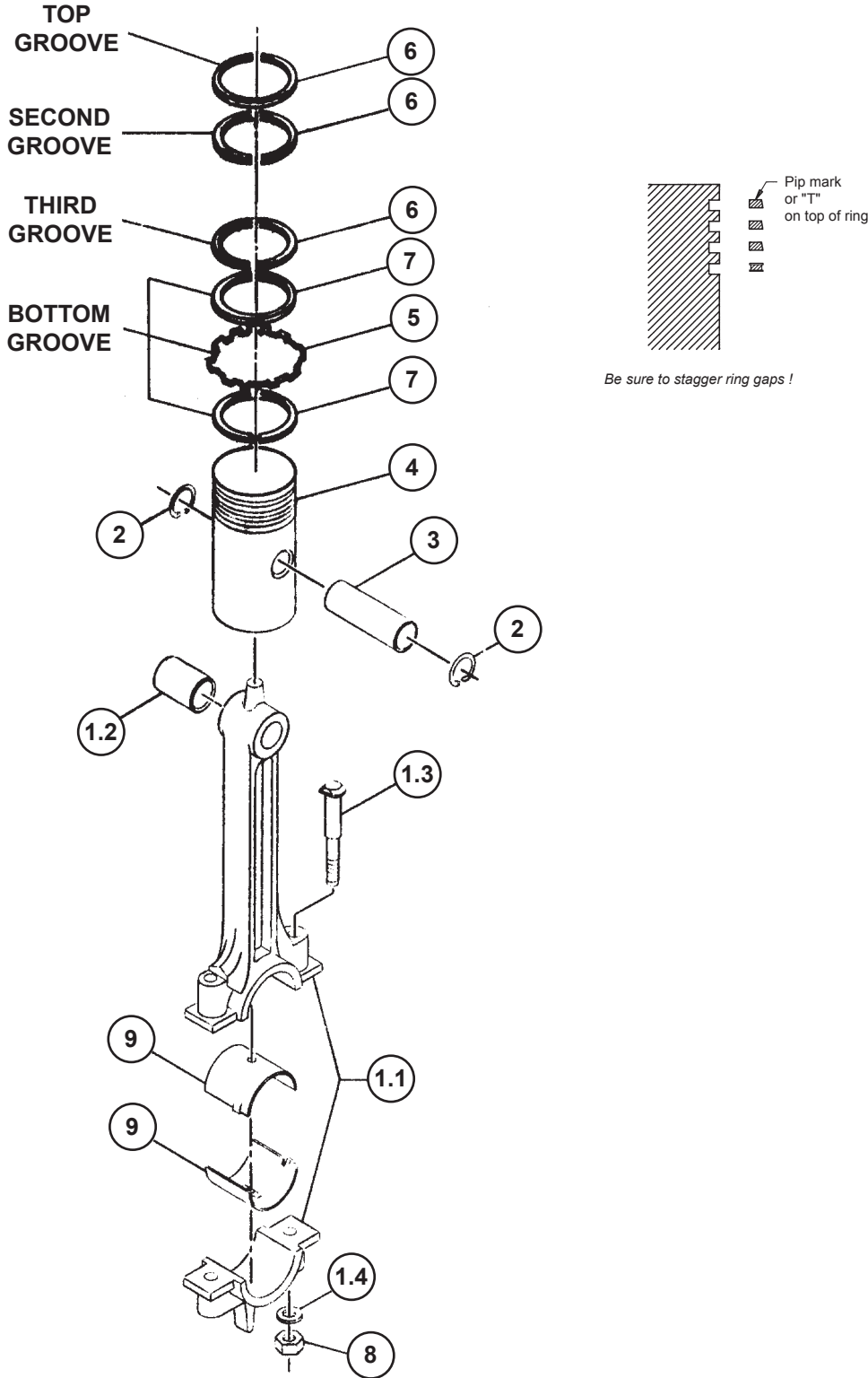



# CONNECTING ROD & PISTON GROUP 110248

(high pressure)

Item Number	Qty.	Part Number	Description
1	1	40201	connecting rod assembly (N.S.S.; order 6442HPX)
1.1	1	6442C- HP	rod, connecting (N.S.S.; see maintenance parts)
1.2	1	6443	bushing, connecting rod (N.S.S.; order 6440SR)
1.3	2	3493	connecting rod bolt
1.4	2	1836	washer
2	2	8648	retaining ring
3	1	110190-021	piston pin
4	1	1530-001	piston , high pressure
5	1	111280	oil ring expander
6	3	1652	piston ring
7	2	111281	oil ring rail
8	2	124471-L08	locknut, 3/8-24 unf (@ 35 ft.-lbs.)
9	2	6444	insert, connecting rod (N.S.S.; see maintenance parts)
<b>Maintenance Parts</b>			
* 9	1	6444PR	inserts, connecting rod (1 pair, standard size)
* 9	1	6444-010PR	inserts, connecting rod (1 pair, .010 undersize)
1.2	1	6440SR	replacement connecting rod bushing
4	1	1530-011	piston, high pressure (.010 oversize)
4	1	1530-021	piston, high pressure (.020 oversize)
	1	<b>8161A</b>	<b>Piston Ring Set (standard)</b> includes piston rings, oil ring rails & expander
	1	<b>4422-010</b>	<b>Piston Ring Set (.010 oversize, light blue color code)</b> includes includes piston rings, oil ring rails & expander
	1	<b>4422-020</b>	<b>Piston Ring Set (.020 oversize, yellow color code)</b> includes includes piston rings, oil ring rails & expander
	1	<b>1530X001</b>	<b>Piston Assembly, high pressure (standard)</b> includes ring set, piston pin, retaining rings, & piston
		<b>1530X011</b>	<b>Piston Assembly, high pressure (.010 oversize)</b> includes ring set, piston pin, retaining rings, & piston
		<b>1530X021</b>	<b>Piston Assembly, high pressure (.020 oversize)</b> includes ring set, piston pin, retaining rings, & piston
		<b>6442HPX</b>	<b>Replacement Connecting Rod Assembly</b> includes connecting rod assembly, connecting rod inserts, & locknuts

N.S.S. = Not Sold Separate

@ Indicates torque value (dry threads). Tighten multiple bolts, capscrews & hex nuts in a criss-cross or alternating pattern. Bring each fastener to the recommended torque specification in even increments.

\* One pair required for each connecting rod assembly.

# CONNECTING ROD & PISTON GROUP 110247

(low pressure)

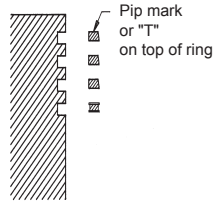

Be sure to stagger ring gaps!

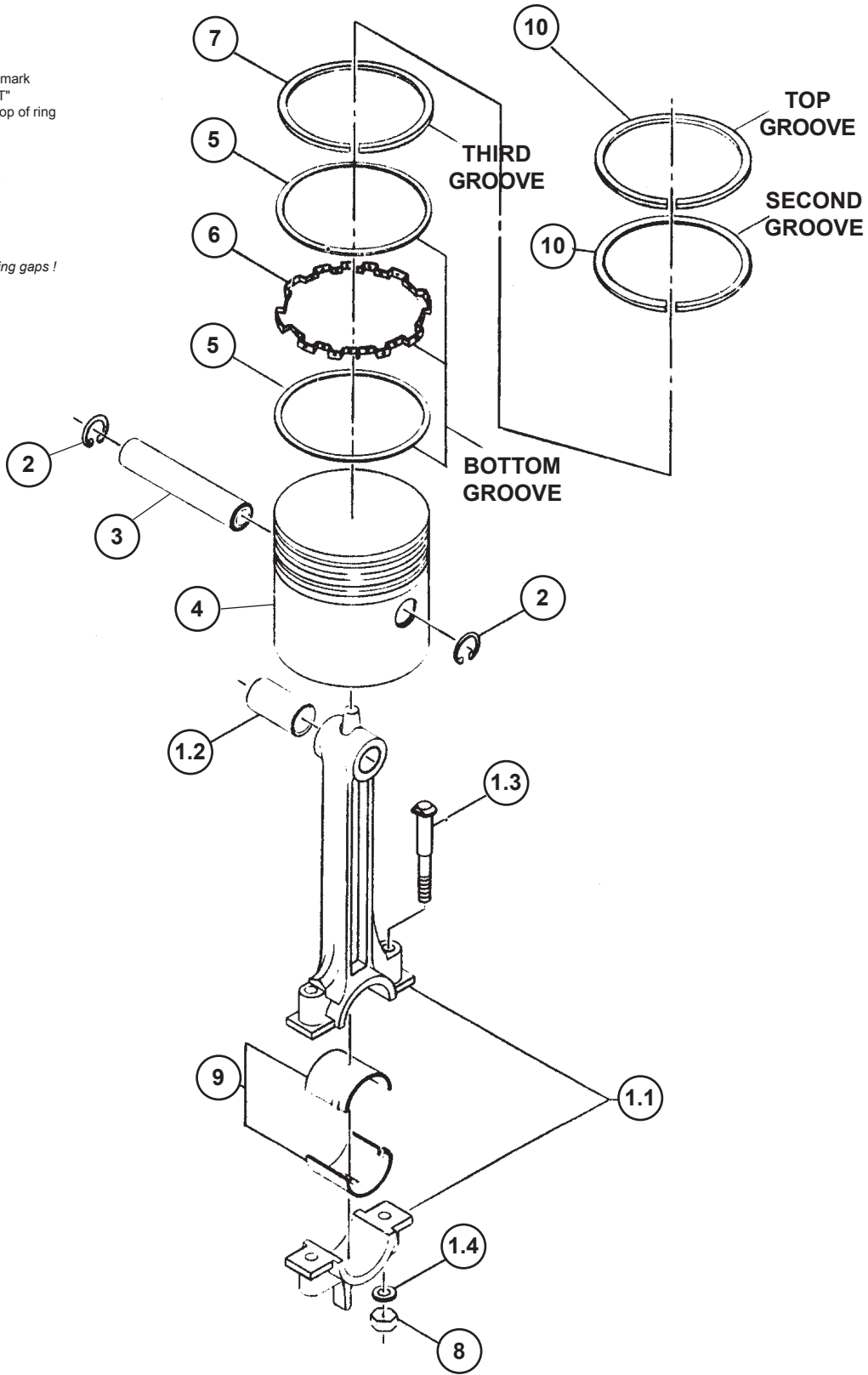

# CONNECTING ROD & PISTON GROUP 110247

(low pressure)

Item Number	Qty.	Part Number	Description
1	1	40139	connecting rod assembly (N.S.S.; see maintenance parts)
1.1	1	6442C	rod, connecting (N.S.S.; see maintenance parts)
1.2	1	6443	bushing, connecting rod (N.S.S.; order 6443SR)
1.3	2	3493	connecting rod bolt
1.4	2	1836	washer
2	2	8648	retaining ring
3	1	8646	piston pin
4	1	8643	piston, low pressure
5	2	112781	oil ring expander
6	1	112780	oil ring rail
7	1	7351	piston ring
8	2	124471-L08	locknut, 3/8-24 unf (@ 35 ft.-lbs.)
9	2	6444	insert, connecting rod (N.S.S.; see maintenance parts)
10	2	2584	piston ring
<b>Maintenance Parts</b>			
* 9	1	6444PR	inserts, connecting rod (1 pair, standard size)
* 9	1	6444-010PR	inserts, connecting rod (1 pair, .010 oversize)
1.2	1	6443SR	replacement connecting rod bushing
4	1	8643-010	piston, low pressure (.010 oversize)
4	1	8643-020	piston, low pressure (.020 oversize)
		<b>8166A</b>	<b>Piston Ring Set (standard)</b> includes piston rings, oil ring expander, & rails
		<b>4434-010</b>	<b>Piston Ring Set (.010 oversize, light blue color code)</b> includes piston rings, oil ring expander, & rails
		<b>4434-020</b>	<b>Piston Ring Set (.020 oversize, yellow color code)</b> includes piston rings, oil ring expander, & rails
		<b>8643X</b>	<b>Piston Assembly, low pressure (standard size)</b> includes piston, piston pin, retaining rings & ring set
		<b>8643X010</b>	<b>Piston Assembly, low pressure (.010 oversize)</b> includes piston, piston pin, retaining rings & ring set
		<b>8643X020</b>	<b>Piston Assembly, low pressure (.020 oversize)</b> includes piston, piston pin, retaining rings & ring set
		<b>6442X</b>	<b>Replacement Connecting Rod Assembly (standard)</b> includes connecting rod assy., connecting rod inserts, & locknuts

N.S.S. = Not Sold Separate

@ Indicates torque value (dry threads). Tighten multiple bolts, capscrews & hex nuts in a criss-cross or alternating pattern. Bring each fastener to the recommended torque specification in even increments.

\* One pair required for each connecting rod assembly.

# CYLINDER & HEAD GROUP 112071

(control version L)

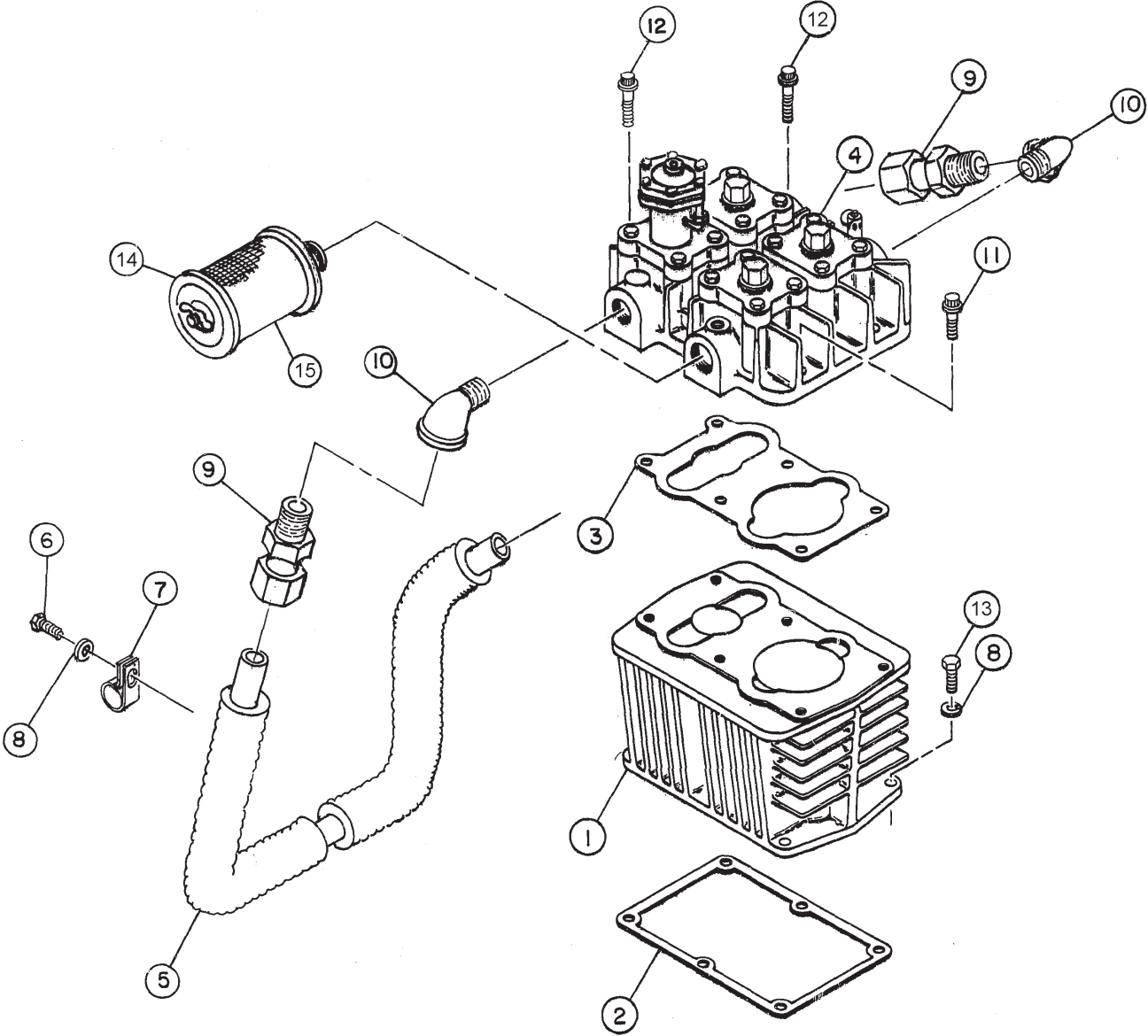

# CYLINDER & HEAD GROUP 112071

(control version L)

Item Number	Qty.	Part Number	Description
1	1	6610-5	cylinder
2	1	1833	gasket, cylinder to crankcase
3	1	7000	gasket
* 4	1	111496U	head assembly (see page 23 for parts breakdown)
5	1	112073	intercooler (N.S.S.; order Intercooler Replacement Kit)
6	1	123478-L10	hex. screw, 3/8-16 unc x .75, grade 5 (@ 30 ft.-lbs.)
7	1	6293-002	clamp
8	7	123115-06C	lockwasher, 3/8
9	2	124393-025	fitting
10	2	3092	pipe elbow, 3/4 npt x 3/4 npt, 90°
11	2	90386-N15	counterbore screw, 1/2-13 unc x 1.50, grade 8 (@ 50 ft.-lbs.)
12	4	90386-N20	counterbore screw, 1/2-13 unc x 2.75, grade 8 (@ 50 ft.-lbs.)
13	6	123478-L14	hex. screw, 3/8-16 unc x 1.25, grade 5 (@ 30 ft.-lbs.)
14	1	110377F100	air filter
14	1	110377H100	filter
14	1	110377S100	air filter/silencer, hooded
15	1	110377E100	air filter element, (fits 110377F100 & 110377S100 filter)
			<b>Maintenance Parts</b>
	1	<b>111496X11L</b>	<b>Replacement Head Assembly</b> includes head assy., head gasket, copper tube & fittings
	1	<b>111496-051</b>	<b>Replacement Head Assembly (for high pressure rated compressors)</b> includes high pressure rated head assy., head gasket, copper tube & fittings
	1	<b>112088</b>	<b>Intercooler Replacement Kit</b> includes intercooler and nut / sleeve fittings

N.S.S. = Not Sold Separate

@ Indicates torque value (dry threads). Tighten multiple bolts, capscrews & hex nuts in a criss-cross or alternating pattern. Bring each fastener to the recommended torque specification in even increments.

\* High pressure compressors and DNV certified applications require 111496HPS head in lieu of 111496 head and 6610-5HPS cylinder in lieu of 6610-5 cylinder

# CYLINDER & HEAD GROUP 112072

(control versions LS & LVD)

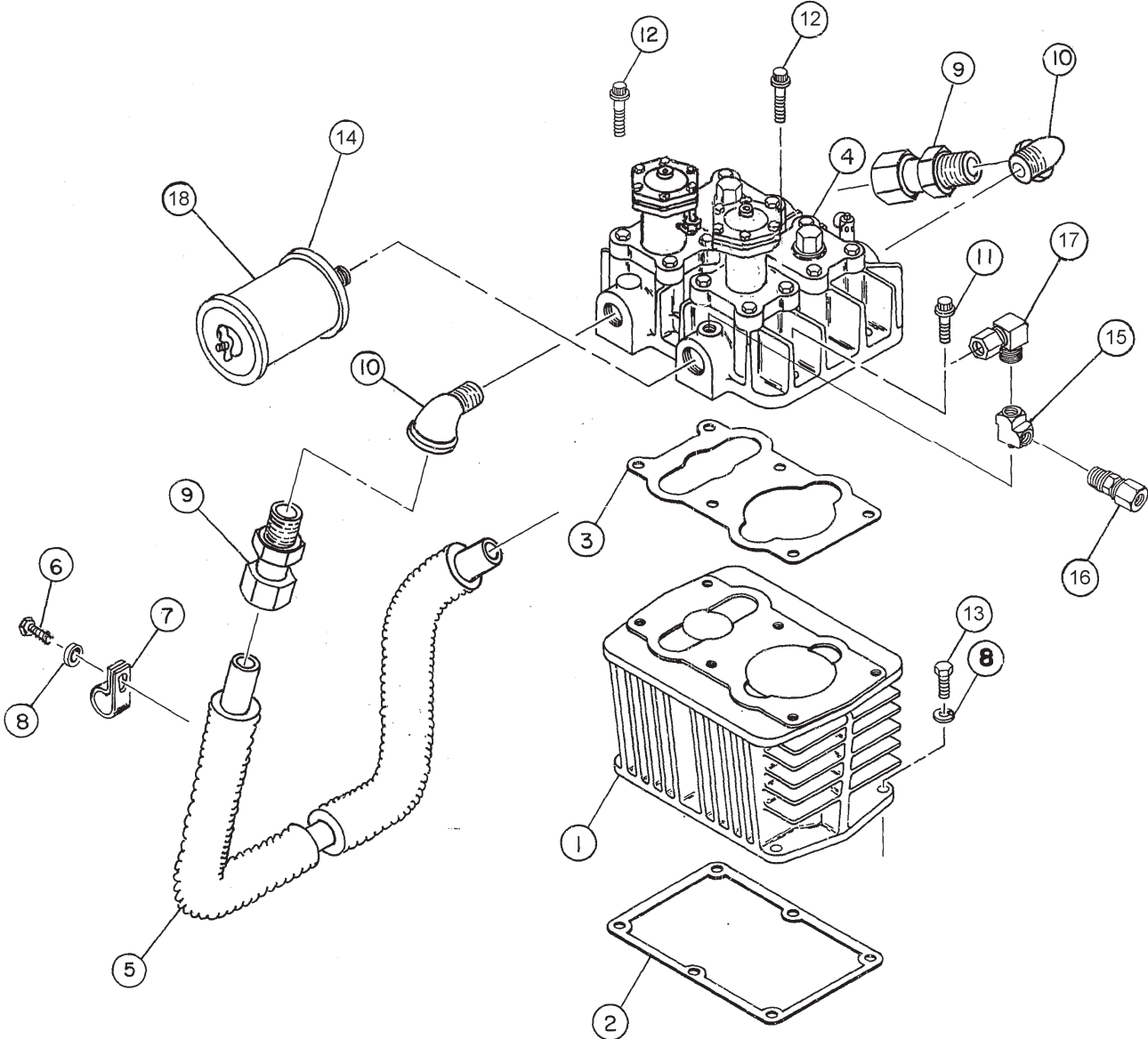

# CYLINDER & HEAD GROUP 112072

(control versions LS & LVD)

Item Number	Qty.	Part Number	Description
1	1	6610-5	cylinder
2	1	1833	gasket, cylinder to crankcase
3	1	7000	gasket
* 4	1	111496UU	head assembly (see page 25 for parts breakdown)
5	1	112073	intercooler (N.S.S.; order Intercooler Replacement Kit)
6	1	123478-L10	hex. screw, 3/8-16 unc x .75, grade 5 (@ 30 ft.-lbs.)
7	1	6293-002	clamp
8	7	123115-06C	lockwasher, 3/8
9	2	124393-025	fitting
10	2	3092	pipe elbow, 3/4 npt x 3/4 npt, 90°
11	2	90386-N15	counterbore screw, 1/2-13 unc x 1.50, grade 8 (@ 50 ft.-lbs.)
12	4	90386-N20	counterbore screw, 1/2-13 unc x 2.75, grade 8 (@ 50 ft.-lbs.)
13	6	123478-L14	hex. screw, 3/8-16 unc x 1.25, grade 5 (@ 30 ft.-lbs.)
14	1	110377F100	air filter
or			
14	1	110377H100	filter
or			
14	1	110377S100	air filter/silencer, hooded
15	1	3003	pipe tee, 1/4 npt x 1/4 npt x 1/4 npt
16	1	2706	connector
17	1	2708	tube fitting, 90° male elbow, 1/4 tube x 1/4 npt
Maintenance Parts			
18	1	110377E100	air filter element, (fits 110377F100 & 110377S100 filter)
	1	<b>111496X11S</b>	<b>Replacement Head Assembly</b> includes head assy., head gasket, copper tube & fittings
	1	<b>111496-052</b>	<b>Replacement Head Assembly (for high pressure rated compressors)</b> includes high pressure rated head assy., head gasket, copper tube & fittings
	1	<b>112088</b>	<b>Intercooler Replacement Kit</b> includes intercooler and nut / sleeve fittings

N.S.S. = Not Sold Separate

@ Indicates torque value (dry threads). Tighten multiple bolts, capscrews & hex nuts in a criss-cross or alternating pattern. Bring each fastener to the recommended torque specification in even increments.

\* High pressure compressors and DNV certified applications require 111496HPS head in lieu of 111496 head and 6610-5HPS cylinder in lieu of 6610-5 cylinder

# HEAD ASSEMBLY 111496U

(control version L)

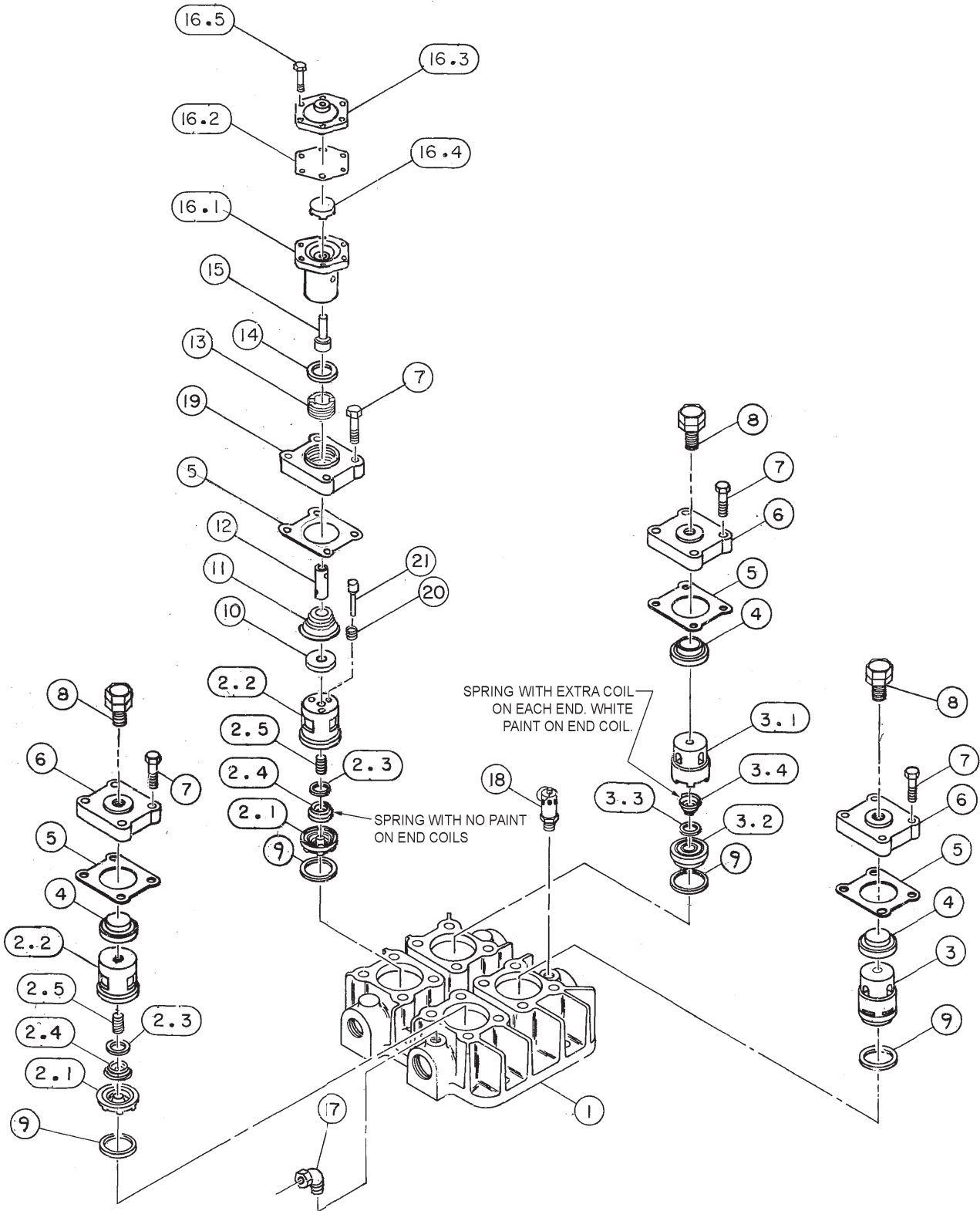



# HEAD ASSEMBLY 111496U

(control version L)

Item Number	Qty.	Part Number	Description
* 1	1	111496	head
2	2	7277X1	valve assembly
2.1	1	7277	valve bumper
2.2	1	1815	seat
2.3	1	1846	valve disc
2.4	1	7270	valve spring
2.5	1	1849	stud
3	2	7271X004	discharge valve assembly
3.1	1	7271-004	discharge valve bumper
3.2	1	1819-002	discharge valve seat
3.3	1	1846	valve disc
3.4	1	7270-2	valve spring
4	3	110639	spacer
5	4	1852	gasket
6	3	5906	valve cover plate
‡ 7	16	7480	hex. screw, 7/16-14 unc x 1.38, grade 5(@ 50 ft.-lbs.)
** 8	3	114545-R15	bolt & jamnut assembly (bolt @ 60 ft.-lbs. - jamnut @ 50 ft.-lbs.)
9	4	1848	gasket
10	1	6925	platform
11	1	6964	spacer
12	1	6965-001	pin
13	1	3008	holddown screw (@ 70 ft.-lbs.)
14	1	1556	gasket
15	1	7532X	unloader piston assembly
16	1	40055	unloader assembly (@ 75 ft.-lbs.) (N.S.S.; order 7483X)
16.1	1	7483	unloader body
16.2	1	1855	diaphragm
16.3	1	1818B	diaphragm cover plate
16.4	1	5910	diaphragm disc
16.5	6	7499	hex. screw, 1/4-20 unc x .75, grade 2 (@ 72 in.-lbs.)
17	1	2710	fitting
18	1	2961-100	pressure relief valve
19	1	6928	plate
20	3	6910	valve spring
21	3	1857	valve pin

### Maintenance Parts

1	<b>111496HPS</b>	<b>Replacement Head (for high pressure rated compressors)</b>
1	<b>7277X</b>	<b>Replacement Suction Valve Assembly</b> includes suction valve assy. & valve gasket
1	<b>7277XU</b>	<b>Replacement Suction Valve Assembly</b> includes suction valve assy., valve gasket, valve pins, & valve springs
2	<b>7271X04</b>	<b>Replacement Discharge Valve Assembly</b> includes discharge valve assy. & valve gasket
1	<b>7483X</b>	<b>Replacement Unloader Assembly</b> includes unloader assembly, unloader piston assembly, valve gasket & pipe plug

Parts for use with diester or phosphate ester synthetic based lubricants

16.2	1	1855S	diaphragm
------	---	-------	-----------

N.S.S. = Not Sold Separate

@ Indicates torque value (dry threads). Tighten multiple bolts, capscrews & hex nuts in a criss-cross or alternating pattern. Bring each fastener to the recommended torque specification in even increments.

\* High pressure compressors and DNV certified applications require 111496HPS head in lieu of 111496 head.

‡ Tighten and torque valve cover plate hex screws (item 7) prior to tightening valve clamp hex screws (item 8).

\*\* Install with Loctite® 272 applied to threads.

# HEAD ASSEMBLY 111496UU

(control versions LS & LVD)

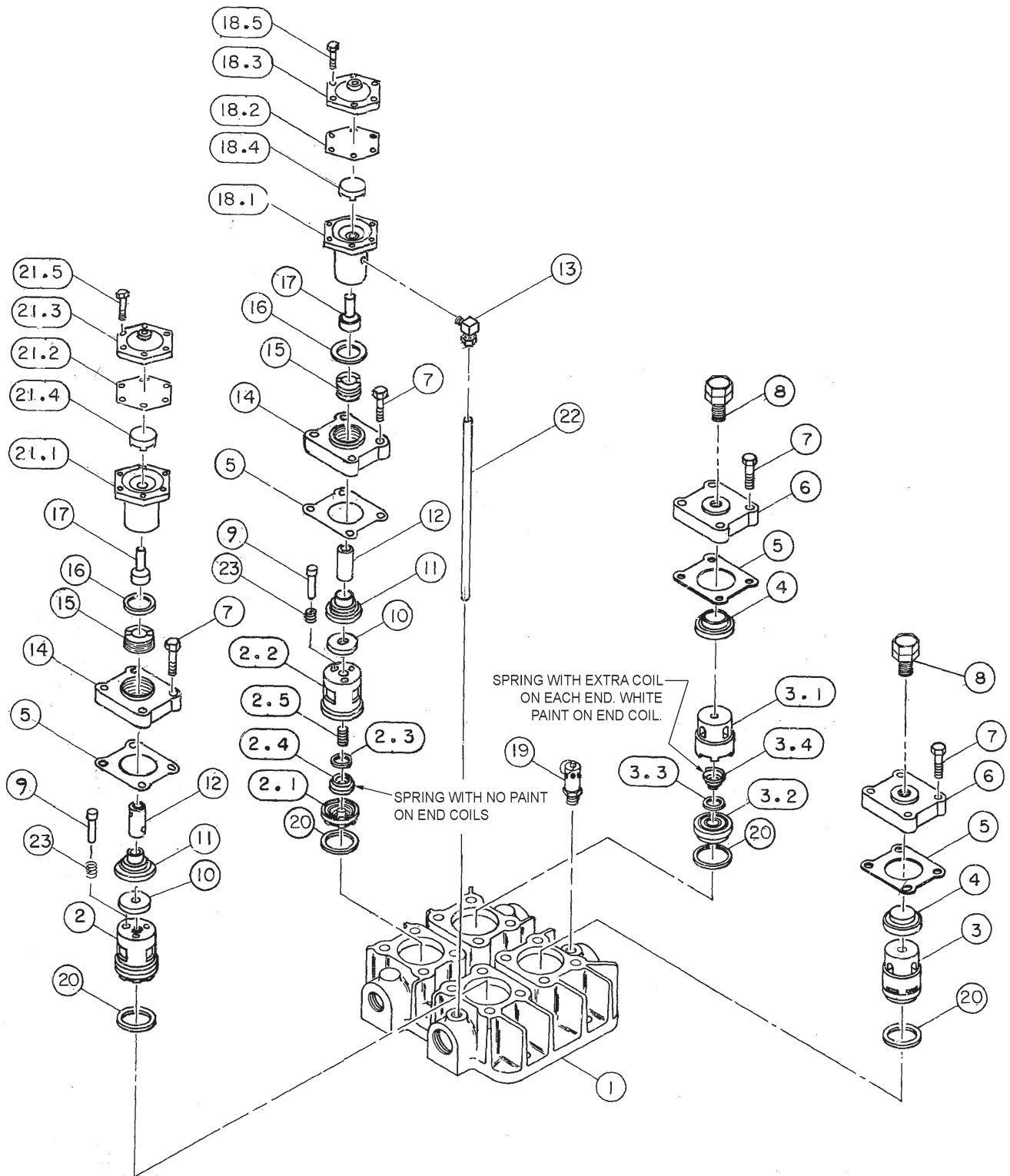

# HEAD ASSEMBLY 111496UU

(control versions LS & LVD)

Item Number	Qty.	Part Number	Description
* 1	1	111496	head
2	2	7277X1	valve assembly
2.1	1	7277	valve bumper
2.2	1	1815	seat
2.3	1	1846	valve disc
2.4	1	7270	valve spring
2.5	1	1849	stud
3	2	7271X004	discharge valve assembly
3.1	1	7271-004	discharge valve bumper
3.2	1	1819-002	discharge valve seat
3.3	1	1846	valve disc
3.4	1	7270-2	valve spring
4	2	110639	spacer
5	4	1852	gasket
6	2	5906	valve cover plate
‡ 7	16	7480	hex. screw, 7/16-14 unc x 1.38, grade 5 (@ 50 ft.-lbs.)
** 8	2	114545-R15	bolt & jamnut assembly (bolt @ 60 ft.-lbs. - jamnut @ 50 ft.-lbs.)
9	6	1857	valve pin
10	2	6925	platform
11	2	6964	spacer
12	2	6965-001	pin
13	1	1642	tube fitting, 90° male elbow, 1/4 tube x 1/8 npt
14	2	6928	plate
15	2	3008	holddown screw (@ 70 ft.-lbs.)
16	2	1556	gasket
17	2	7532X	unloader piston assembly
18	1	40055	unloader assembly (@ 75 ft.-lbs.) (N.S.S.; order 7483X)
18.1	1	7483	unloader body
18.2	1	1855	diaphragm
18.3	1	1818B	diaphragm cover plate
18.4	1	5910	diaphragm disc
18.5	6	7499	hex. screw, 1/4-20 unc x .75, grade 2 (@ 72 in.-lbs.)
19	1	2961-100	pressure relief valve
20	4	1848	gasket
21	1	40192	unloader assembly (@ 75 ft.-lbs.), (N.S.S.; order 8272X)
21.1	1	8272	unloader body
21.2	1	1855	diaphragm
21.3	1	1818B	diaphragm cover plate
21.4	1	5910	diaphragm disc
21.5	6	7499	hex. screw, 1/4-20 unc x .75, grade 2 (@ 72 in.-lbs.)
22	1 ft.	110515-025	copper tube, 1/4 o.d.
23	6	6910	valve spring

### Maintenance Parts

1	<b>111496HPS</b>	<b>Replacement Head (for high pressure rated compressors)</b>
1	<b>7277X</b>	<b>Replacement Suction Valve Assembly</b> includes suction valve assy. & valve gasket
2	<b>7277XU</b>	<b>Replacement Suction Valve Assembly</b> includes suction valve assy., valve gasket, valve pins & valve springs
2	<b>7271X04</b>	<b>Replacement Discharge Valve Assembly</b> includes discharge valve assy. & valve gasket
1	<b>7483X</b>	<b>Replacement Unloader Assembly</b> includes unloader assy. (40055), unloader piston assy., valve gasket & pipe plug
1	<b>8272X</b>	<b>Replacement Unloader Assembly</b> includes unloader piston assembly, unloader assembly (40192), & valve gasket
18.2 & 21.2	1	Parts for use with diester or phosphate ester synthetic based lubricants 1855S diaphragm

N.S.S. = Not Sold Separate

@ Indicates torque value (dry threads). Tighten multiple bolts, capscrews & hex nuts in a criss-cross or alternating pattern. Bring each fastener to the recommended torque specification in even increments.

\* High pressure compressors and DNV certified applications require 111496HPS head in lieu of 111496 head.

‡ Tighten and torque valve cover plate hex screws (item 7) prior to tightening valve clamp hex screws (item 8).

\*\* Install with Loctite® 272 applied to threads.

# CONTROL GROUP 110855

(control version L)

Item Number	Qty.	Part Number	Part Number	Description
		<b>0-200 PSI</b>	<b>201-500 PSI</b>	
1	1	110827-001	110827-002	hydraulic unloader assembly
2	3	1642	1642	tube fitting, 90° male elbow, 1/4 tube x 1/8 npt
3	3 ft.	110515-025	110515-025	copper tube, 1/4 o.d.
		<b>113225</b>	<b>113225</b>	<b>Maintenance Parts</b> <b>Hydraulic Unloader Repair Kit</b> includes diaphragm, stem assembly, inlet filter & fitting assembly, spring (0-200 PSI) and spring (201-500 PSI, red color code)
		Parts for use with diester or phosphate ester synthetic based lubricants		
1	1	110827-003		hydraulic unloader assembly (standard, 0-200 PSI)
1	1		110827-004	hydraulic unloader assembly (high pressure, 201-500 PSI)

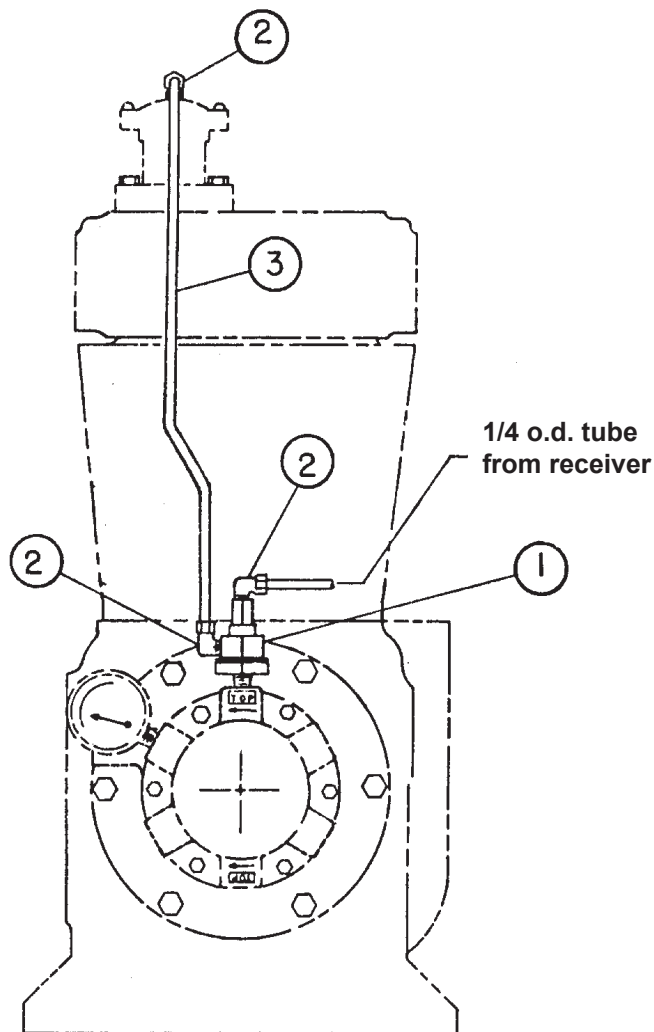

# CONTROL GROUP 2023903355

(control version LS)

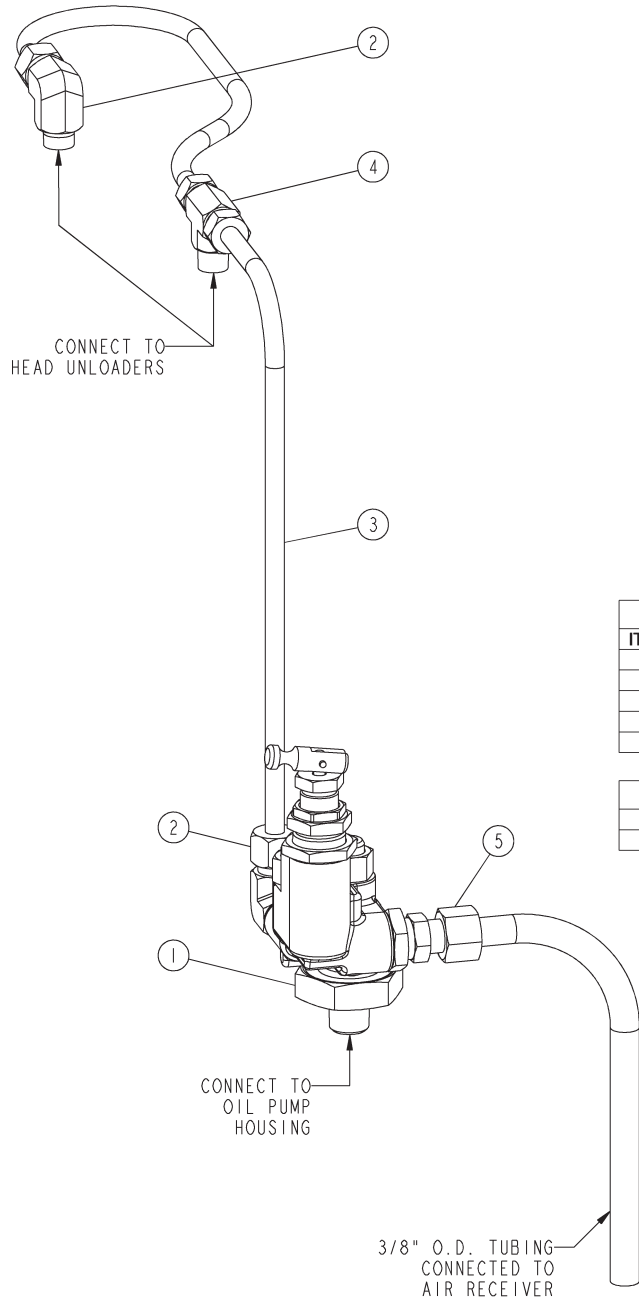

2023903355 LS CONTROL GROUP (STANDARD 165-175 PSI)			
ITEM	PART NUMBER	QTY	DESCRIPTION
1	2023903305	1	LS CONTROL VALVE, 165-175 PRESET
2	1642	2	TUBE FITTING, 90° ELBOW, 1/4TX1/8MP
3	110515-025	1	1/4" COPPER TUBING - 5 FT.
4	1665	1	MALE BRANCH TEE 1/4T X 1/8P
5	2616	1	TUBE FITTING, STRAIGHT, 3/8 TUBE X 1/4 NPT

MAINTENANCE PARTS	
PART NUMBER	DESCRIPTION
2023903290	CONTROL VALVE INLET FILTER

\* See page 21 for optional pilot valves that must be used with respective pressure ranges.

# CONTROL GROUP 2023903255

(control version LVD)

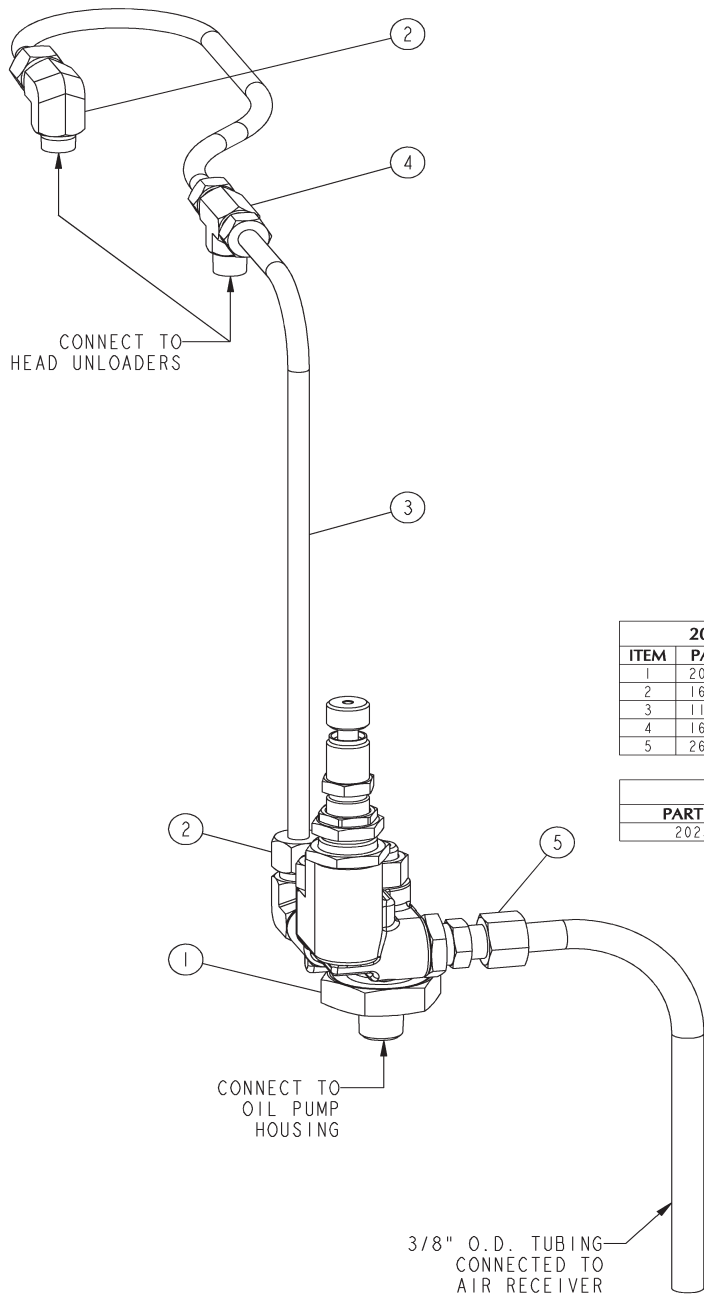

2023903255 LVD CONTROL GROUP (STANDARD 155-165 PSI)			
ITEM	PART NUMBER	QTY	DESCRIPTION
1	2023903205	1	LVD CONTROL VALVE, 155-165 PRESET
2	1642	2	TUBE FITTING, 90° ELBOW, 1/4T x 1/8MP
3	110515-025	1	1/4" COPPER TUBING - 5 FT.
4	1665	1	MALE BRANCH TEE 1/4T X 1/8P
5	2616	1	TUBE FITTING, STRAIGHT, 3/8 TUBE X 1/4 NPT

MAINTENANCE PARTS	
PART NUMBER	DESCRIPTION
2023903290	CONTROL VALVE INLET FILTER

\* See page 21 for optional pilot valves that must be used with respective pressure ranges.

# PILOT VALVES

## COMBINATION VALVES - CONTROL VERSION "LVD" CONTAINS THE HYDRAULIC UNLOADER, PILOT VALVE, AND CHECK VALVE IN A SINGLE PART

	<b>PILOT SETTINGS</b>	<b>QUINCY PART #</b>	<b>FACTORY PRE-SET:</b>		<b>*CUSTOMER RE-SETTABLE:</b>		
	SEE WARNING BELOW		<b>LOAD PRESSURE (PSI)</b>	<b>UNLOAD PRESSURE (PSI)</b>	<b>LOAD PRESSURE RANGE (PSI)</b>	<b>UNLOAD PRESSURE RANGE (PSI)</b>	
	CUSTOM PRESSURE SETTING		2023903201	100	115	**	51-120
			2023903202	130	140	**	121-250
			2023903203	450	500	**	251-500
STANDARD 1-STAGE COMPRESSOR	2023903204	85	95	**	51-120		
STANDARD 2-STAGE COMPRESSOR	2023903205	155	165	**	121-250		

## COMBINATION VALVES - CONTROL VERSION "LS" CONTAINS THE HYDRAULIC UNLOADER, PILOT VALVE, AND CHECK VALVE IN A SINGLE PART

	<b>PILOT SETTINGS</b>	<b>QUINCY PART #</b>	<b>FACTORY PRE-SET:</b>		<b>*CUSTOMER RE-SETTABLE:</b>		
	SEE WARNING BELOW		<b>LOAD PRESSURE (PSI)</b>	<b>UNLOAD PRESSURE (PSI)</b>	<b>LOAD PRESSURE RANGE (PSI)</b>	<b>UNLOAD PRESSURE RANGE (PSI)</b>	
	CUSTOM PRESSURE SETTING		2023903301	100	110	**	51-120
			2023903302	130	140	**	121-250
			2023903303	450	500	**	251-500
STANDARD 1-STAGE COMPRESSOR	2023903304	90	100	**	51-120		
STANDARD 2-STAGE COMPRESSOR	2023903305	165	175	**	121-250		

\* THE PILOT IS SUPPLIED PRESET FROM THE FACTORY. IF THE PILOT NEEDS TO BE RESET, REFER TO THE QR-25 SERIES INSTRUCTION MANUAL FOR INSTRUCTIONS.

\*\* SEE DIFFERENTIAL SETTING CHART. LOAD PRESSURE = UNLOAD PRESSURE - DIFFERENTIAL.

UNLOAD PRESSURE (PSI)	DIFFERENTIAL MIN-MAX (PSI)
51-175	10-15
175-250	15-25
251-500	25-50

**WARNING!**  
NOT ALL PILOTS ARE FOR USE WITH ALL COMPRESSOR SYSTEMS. MAKE SURE THAT THE PILOT YOU ORDER IS SET WITHIN THE SAFE OPERATING LIMITS OF YOUR COMPRESSOR. FAILURE TO HEED THIS WARNING COULD RESULT IN AN EXPLOSION.  
REFER TO THE "INTRODUCTION" SECTION OF YOUR PARTS MANUAL FOR THE SAFE OPERATING LIMITS OF YOUR COMPRESSOR.

# SUCTION VALVE UNLOADER ASSEMBLIES

## Description

The Quincy suction valve unloader assembly consists of unloading arrangements on the suction valves, having a plunger to contact the suction valve disc and an unloader pilot valve to automatically regulate the passing of receiver pressure to the unloading arrangement.

## Application

Suction valve unloader assemblies are recommended for use on Quincy compressors where the compressor is to run continuously and a constant pressure is to be maintained. The purpose is to automatically unseat the suction valve of the compressor when the air supply is greater than the demand.

## Operation

Unloading occurs when receiver pressure is sufficient to overcome pilot valve spring pressure. The check ball is then unseated, allowing receiver pressure to pass to the unloading arrangements. The compressor will run unloaded until the receiver pressure drops to a predetermined level. At this time, the action of the ball is reversed, shutting off receiver pressure to the unloader arrangement and venting the unloader to atmosphere. This allows the compressor to load. The drive, either electric motor or combustion engine, runs continuously and must be started and stopped manually.

The LS control version is equipped with a toggle lever on the pilot valve which can be flipped to provide manual unloading.

The LVD control version is designed to provide a choice between "start/stop" or "continuous run" operation. The LVD pilot valve can be set for "start/stop" operation by turning the knurled knob at the end of the pilot valve clockwise until it stops. Under these circumstances a pressure switch is required to stop the motor. Failure to use a pressure switch, with the pilot valve locked out, could result in unsafe conditions.

### **WARNING !**

**A pressure switch must be incorporated whenever an LVD pilot valve is employed as part of the control system.**

The compressor will operate in the continuous run mode if the knurled knob on the LVD pilot valve is turned counterclockwise until it stops.

## Installation

The pilot valve is to be connected to the air receiver using a minimum of 3/8" o.d. copper tube. Compressors in the field, not equipped with a suction valve unloader assembly, can be converted to constant speed. Consult your local Quincy distributor for assistance with conversion procedures.

## Service

Periodically check the filter & screens in the inlet of the pilot valve to make sure they are free of obstructions. If they become clogged, remove and clean or replace. Inspect the "o" ring located in the opposite end of the pilot valve body for wear or damage; replace if necessary.

## Adjustment

The unloading pressure is adjustable and is regulated by turning the hex nut (marked "unload adj." in cross sectional illustrations of pilot valves). Turn the hex nut clockwise to increase and counterclockwise to decrease the unloading pressure.

The differential (difference between unloading and loading pressure) is set by turning the hex nut marked "differential adjustment" in the illustrations of the pilot valves on previous pages. Increase the differential pressure by turning the hex nut clockwise - decrease by turning counterclockwise. Tighten the locknuts after adjustment.



<b>Head Kit K325A</b>			
Item #	Qty.	Part Number	Description
1		110377E100	air filter element
2		1556	gasket
2		1855	diaphragm
4		1848	gasket, valve
4		1852	gasket, valve cover
2		1556	gasket, valve cover
4		1846	valve disc
1		7000	gasket, cylinder to head
2		7270	valve spring
2		7270-2	valve spring
1		5700	gasket, intercooler

<b>Yearly Maintenance Kit 110516-325</b>			
Item #	Qty.	Part Number	Description
1		110822	oil pressure gauge
2		1855	diaphragm
6		1857	valve pin
4		1846	valve disc
2		6283	hydraulic unloader filter
6		6910	valve spring
2		7270	valve spring
2		7270-2	valve spring
1		7126	gasket set

<b>Overhaul Kit K325B</b>			
Item #	Qty.	Part Number	Description
1		110377E100	air filter element
2		1855	diaphragm
4		1846	valve disc
2		6444PR	connecting rod inserts (1 pair)
2		7270	valve spring
2		7270-2	valve spring
1		7126	gasket set
1		8161A	ring set
1		8166A	ring set
1		6316	oil seal

<b>Oil Pump Repair Kit 2022132203</b>			
Item #	Qty.	Part Number	Description
1		22749-152	"o"ring
1		22749-112	"o"ring
1		22749-011	"o"ring
1		160003	oil pump gerotor
1		160075-001	key
1		6285	retaining ring
1		2024200202	driveshaft

<b>Basic Compressor Repair Kit 2022118438</b>			
Item #	Qty.	Part Number	Description
1		110190-021	piston pin
1		110377E100	air filter element
1		110610-002	"o"ring kit
1		2023400100	oil filter
1		2720	bearing cup
1		2585	bearing cone
1		2523	bearing cup
1		2788	bearing cone
2		6443SR	connecting rod bushing
2		6444PR	connecting rod inserts (1 pair)
2		7270	valve spring
2		7270-2	valve spring
1		8161	ring set
4		1846	valve disc
1		7126	gasket set
1		8646	piston pin
1		8166	ring set

<b>Overhaul Kit K325C</b>			
Item #	Qty.	Part Number	Description
2		6444PR	con-rod bearing
1		110377E100	air filter element
1		110610-001	"o"ring kit
1		8161	ring set
1		8166	ring set
1		7126	gasket set
4		1846	valve disc
2		7270	spring
2		7270-2	valve spring

<b>Gasket Set 7126</b>			
Item #	Qty.	Part Number	Description
2		1556	gasket
1		1833	gasket, cylinder to crankcase
1		1840	gasket, inspection plate
4		1848	gasket
4		1852	gasket
2		5700	gasket
2		6294	bearing adj. shim, .005 steel
2		6294A	bearing adj. shim, .007 steel
1		6294B	bearing adj. shim, .020 steel
6		6294C	bearing adj. shim, .005 paper
2		6294D	bearing adj. shim, .002 steel
1		6312	gasket, bearing carrier
1		7000	gasket

Recommended Spare Parts			
Item #	Qty.	Part Number	Description
	2	7277XU	replacement suction valve assy.
	2	7271X04	replacement discharge valve assy.
	1	110822	pressure gauge
	1	2022132203	oil pump repair kit
	1	7126	gasket set
	1	113225	hydraulic unloader repair kit
	2	6444PR	connecting rod inserts (1 pair)
	2	1855	unloader diaphragm
	1	2023903290	control valve inlet filter
	1	110377E100	air filter element

## DECALS

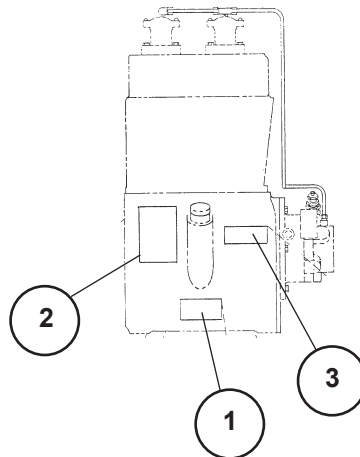

Decals for QR 325 Basic Compressor			
Item #	Qty.	Part Number	Description
1	1	110831	serial number & nameplate
2	1	127889-A	decal, CAUTION!/manual/ "Failure to follow..."
3	1	127889-B	decal, DANGER! / "Air used for breathing..."

\* Not sold separate; order 127889.

# TYPICAL UNIT REPAIR PARTS LIST

The parts listed here are for standard QR 325 (up to 175 PSI) units and may or may not be applicable to custom built units. Check with your local authorized Quincy distributor for parts that can be used for custom built units. Make sure the components you order are rated within the safe operating limits of your system. If you are doubtful about which components to order, contact your local Quincy distributor.

## (QR 325 simplex - horizontal tank - electric motor)

Qty	Part Number	Part Number	Part Number	Description
	<b>60 gal.</b>	<b>80 gal.</b>	<b>120 gal.</b>	
1	113891-200	113268-200	113271-200	tank (200 PSI max. working pressure)
1	n/a	n/a	*113281	top plate
1	2713	2713	111136-050	tank drain valve
1	111136-075	111136-075	111136-100	ball valve
1	110514-300	110514-300	110514-300	pressure gauge
1	110512-003	110512-003	§110512-003	pressure switch (135-175 PSI)
1	110513-200	110513-200	110513-200	pressure relief valve (200 PSI)
3 ft.	110515-075	110515-075	110515-075	discharge tube (3/4" copper tube to be formed by customer)
2	23271	23271	23271	compression fittings
	<b>3 h.p.</b>	<b>5 h.p.</b>		
1	110357B065	110357B068		drive belt
1	110580-118	115240		motor pulley
1	n/a	8928		motor pulley bushing
1	113242K001	113242K001		belt guard assembly
	<b>115/230v, 1Ø</b>	<b>200v, 3Ø</b>	<b>230/460v, 3Ø</b>	
1	4003	8098	124517-006	3 h.p. motor (ODP)
1	**127466I020	8099	124517-005	5 h.p. motor (ODP)

\* 113281 top plate is also used for all QR 325 base mounted electric motor driven units.

! Pre-formed discharge tubes are available. Contact factory with model & tank size information.

\*\* 230 volt only.

§ 2298-175 pressure switch on base mounted unit.

## (QR 325 duplex - horizontal tank - electric motor)

Qty	Part Number	Part Number	Part Number	Description
	<b>80 gal.</b>	<b>120 gal.</b>	<b>200 gal.</b>	
1	113471-200	113467-200	113469-200	tank (200 p.s.i. max. working pressure)
2	N/A	113281	113281	top plate
1	2713	111136-050	111136-050	tank drain valve
1	111136-075	111136-100	111136-100	ball valve
1	110514-300	110514-300	110514-300	pressure gauge
2	110512-003	110512-003	110512-003	pressure switch (135-175 PSI)
1	110513-200	110513-200	110513-200	pressure relief valve (200 PSI)
6 ft.	110515-075	110515-075	110515-075	discharge tube (3/4" copper tube to be formed by customer)
4	23271	23271	23271	compression fittings
	<b>3 h.p.</b>	<b>5 h.p.</b>		
2	110357B065	110357B068		drive belt
2	110580-118	115240		motor pulley
2	n/a	8928		motor pulley bushing
2	113242K001	113242K001		belt guard assembly
	<b>115/230v, 1Ø</b>	<b>200v, 3Ø</b>	<b>230/460v, 3Ø</b>	
2	4003	8098	124517-006	3 h.p. motor (ODP)
2	*127466I020	8099	124517-005	5 h.p. motor (ODP)

! Pre-formed discharge tubes are available. Contact factory with model & tank size information.

\* 230 volt only.

# TYPICAL UNIT REPAIR PARTS LIST

The parts listed here are for standard QR 325 (up to 175 PSI) units and may or may not be applicable to custom built units. Check with your local authorized Quincy distributor for parts that can be used for custom built units. Make sure the components you order are rated within the safe operating limits of your system. If you are doubtful about which components to order, contact your local Quincy distributor.

## (QR 325 vertical tank - electric motor)

Qty	Part Number	Part Number	Part Number	Description
	<b>60 gal.</b>	<b>80 gal.</b>		
1	114948P200	114949P200		tank (200 PSI max. working pressure)
1	110425-025	110425-050		tank drain valve
1	111136-075	111136-075		ball valve
1	110514-300	110514-300		pressure gauge
1	110512-003	110512-003		pressure switch (135-175 PSI)
1	110513-200	110513-200		pressure relief valve (200 PSI)
3 ft.	110515-075	110515-075		! discharge tube (3/4" copper tube to be formed by customer)
2	23271	23271		compression fittings
	<b>3 h.p.</b>	<b>5 h.p.</b>		
1	110357B065	110357B068		drive belt
1	110580-118	115240		motor pulley
1	n/a	8928		motor pulley bushing
1	113242K001	113242K001		belt guard assembly
	<b>115/230v, 1Ø</b>	<b>200v, 3Ø</b>	<b>230/460v, 3Ø</b>	
1	4003	8098	124517-006	3 h.p. motor (ODP)
1	*127466I020	8099	124517-005	5 h.p. motor (ODP)

! Pre-formed discharge tubes are available. Contact factory with model & tank size information.

\* 230 volt only.

## (QR 325 gasoline engine driven - Kohler)

Qty	Part Number	Part Number	Part Number	Description
	<b>base unit</b>	<b>tank unit</b>		
1		113727P200		tank (200 PSI)
1	113764			top plate
1		111136-025		tank drain valve
1		111136-050		ball valve
1		110514-300		pressure gauge
1		110513-200		pressure relief valve (200 PSI)
2	110258B074	110258B074		drive belt
1	5629	5629		engine pulley
1	8927	8927		engine pulley bushing
1	113702K005	113702K005		belt guard assembly
1	113143-003	113143-003		throttle control, bullwhip cable
1	113698	113698		Kohler engine group, 11 h.p. (includes exhaust system & throttle control)
3 ft.		110515-075		! discharge tube (3/4" copper tube to be formed by customer)
2		23271		compression fittings

! Pre-formed discharge tubes are available. Contact factory with model & tank size information.

# TYPICAL UNIT REPAIR PARTS LIST

The parts listed here are for standard QR 325 (up to 175 PSI) units and may or may not be applicable to custom built units. Check with your local authorized Quincy distributor for parts that can be used for custom built units. Make sure the components you order are rated within the safe operating limits of your system. If you are doubtful about which components to order, contact your local Quincy distributor.

(QR 325 gasoline engine driven - Honda)

Qty	Part Number	Part Number	Part Number	Description
	<b>base unit</b>	<b>tank unit</b>		
1		113727P200		tank (200 PSI)
1	113764			top plate
1		111136-025		tank drain valve
1		111136-050		ball valve
1		110514-300		pressure gauge
1		110513-200		pressure relief valve (200 PSI)
2	110258B074	110258B074		drive belt
1	5629	5629		engine pulley
1	8927	8927		engine pulley bushing
1	113702-012	113702-012		belt guard assembly
1	113143-002	113143-002		throttle control, bullwhip cable
1	113700-1	113700-1		Honda engine group, 11 h.p. (includes engine & throttle control)
1		112266-323		! discharge piping group (includes discharge piping and fittings- 3/4" copper tube to be formed by customer)

! Pre-formed discharge tubes are available. Contact factory with model & tank size information.

(QR 325 diesel engine driven - Yanmar)

Qty	Part Number	Part Number	Part Number	Description
	<b>base unit</b>	<b>tank unit</b>		
1		113727P200		tank (200 PSI)
1	113764			base
1		111136-025		tank drain valve
1		111136-050		ball valve
1		110514-300		pressure gauge
1		110513-200		pressure relief valve (200 PSI, in tank)
2	110258B074	110258B074		drive belt
1	5629	5629		engine pulley
1	8927	8927		engine pulley bushing
1	113702K008	113702K008		belt guard assembly
1	113143-001	113143-001		throttle control
1	114080-002	114080		Yanmar diesel engine group, 10 h.p. (includes throttle control)
2.5 ft.		110515-075		! discharge tube (3/4" copper tube to be formed by customer)
2		23271		compression fittings

! Pre-formed discharge tubes are available. Contact factory with model & tank size information.

# QUINCY COMPRESSOR STANDARD TERMS AND CONDITIONS

**LEGAL EFFECT:** Except as expressly otherwise agreed to in writing by an authorized representative of Seller, the following terms and conditions shall apply to and form a part of this order and any additional and/or different terms of Buyer's purchase order or other form of acceptance are rejected in advance and shall not become a part of this order.

The rights of Buyer hereunder shall be neither assignable nor transferable except with the written consent of Seller.

This order may not be canceled or altered except with the written consent of Seller and upon terms which will indemnify Seller against all loss occasioned thereby. All additional costs incurred by Seller due to changes in design or specifications, modification of this order or revision of product must be paid for by Buyer.

In addition to the rights and remedies conferred upon Seller by this order, Seller shall have all rights and remedies conferred at law and in equity and shall not be required to proceed with the performance of this order if Buyer is in default in the performance of such order or of any other contract or order with seller.

**TERMS OF PAYMENT:** Unless otherwise specified in the order acknowledgment, the terms of payment shall be 1% 15, net forty-five (45) days after shipment. These terms shall apply to partial as well as complete shipments. If any proceeding be initiated by or against Buyer under any bankruptcy or insolvency law, or in the judgment of Seller the financial condition of Buyer, at the time the equipment is ready for shipment, does not justify the terms of payment specified, Seller reserves the right to require full payment in cash prior to making shipment. If such payment is not received within fifteen (15) days after notification of readiness for shipment, Seller may cancel the order as to any unshipped item and require payment of its reasonable cancellation charges.

If Buyer delays shipment, payments based on date of shipment shall become due as of the date when ready for shipment. If Buyer delays completion of manufacture, Seller may elect to require payment according to percentage of completion. Equipment held for Buyer shall be at Buyer's risk and storage charges may be applied at the discretion of Seller.

Accounts past due shall bear interest at the highest rate lawful to contract for but if there is no limit set by law, such interest shall be eighteen percent (18%). Buyer shall pay all cost and expenses, including reasonable attorney's fees, incurred in collecting the same, and no claim, except claims within Seller's warranty of material or workmanship, as stated below, will be recognized unless delivered in writing to Seller within thirty (30) days after date of shipment.

**TAXES:** All prices exclude present and future sales, use, occupation, license, excise, and other taxes in respect of manufacture, sales or delivery, all of which shall be paid by Buyer unless included in the purchase price at the proper rate or a proper exemption certificate is furnished.

**ACCEPTANCE:** All offers to purchase, quotations and contracts of sales are subject to final acceptance by an authorized representative at Seller's plant.

**DELIVERY:** Except as otherwise specified in this quotation, delivery will be F. O. B. point of shipment. In the absence of exact shipping instruction, Seller will use its discretion regarding best means of insured shipment. No liability will be accepted by Seller for so doing. All transportation charges are at Buyer's expense. Time of delivery is an estimate only and is based upon the receipt of all information and necessary approvals. The shipping schedule shall not be construed to limit seller in making commitments for materials or in fabricating articles under this order in accordance with Seller's normal and reasonable production schedules.

Seller shall in no event be liable for delays caused by fires, acts of God, strikes, labor difficulties, acts of governmental or military authorities, delays in transportation or procuring materials, or causes of any kind beyond Seller's control. No provision for liquidated damages for any cause shall apply under this order. Buyer shall accept delivery within thirty (30) days after receipt of notification of readiness for shipment. Claims for shortages will be deemed to have been waived if not made in writing with ten (10) days after the receipt of the material in respect of which any such shortage is claimed. Seller is not responsible for loss or damage in transit after having received "In Good Order" receipt from the carrier. All claims for loss or damage in transit should be made to the carrier.

**TITLE & LIEN RIGHTS:** The equipment shall remain personal property, regardless of how affixed to any realty or structure. Until the price (including any notes given therefore) of the equipment has been fully paid in cash, Seller shall, in the event of Buyer's default, have the right to repossess such equipment.

**PATENT INFRINGEMENT:** If properly notified and given an opportunity to do so with friendly assistance, Seller will defend Buyer and the ultimate user of the equipment from any actual or alleged infringement of any published United States patent by the equipment or any part thereof furnished pursuant hereto (other than parts of special design, construction, or manufacture specified by and originating with Buyer), and will pay all damages and costs awarded by competent court in any suit thus defended or of which it may have had notice and opportunity to defend as aforesaid.

**STANDARD WARRANTY:** Seller warrants that products of its own manufacture will be free from defects in workmanship and materials under normal use and service for the period specified in the product instruction manual. Warranty for service parts will be Ninety (90) days from date of factory shipment. Electric Motors, gasoline and diesel engines, electrical apparatus and all other accessories, components and parts not manufactured by Seller are warranted only to the extent of the original manufacturer's warranty.

Notice of the alleged defect must be given to the Seller, in writing with all identifying details including serial number, type of equipment and date of purchase within thirty (30) days of the discovery of the same during the warranty period.

Seller's sole obligation on this warranty shall be, at its option, to repair or replace or refund the purchase price of any product or part thereof which proves to be defective. If requested by Seller, such product or part thereof must be promptly returned to seller, freight prepaid, for inspection.

Seller warrants repaired or replaced parts of its own manufacture against defects in materials and workmanship under normal use and service for ninety (90) days or for the remainder of the warranty on the product being repaired.

This warranty shall not apply and Seller shall not be responsible or liable for:

- (a) Consequential, collateral or special losses or damages;
- (b) Equipment conditions caused by fair wear and tear, abnormal conditions of use, accident, neglect or misuse of equipment, improper storage or damage resulting during shipping;
- (c) Deviation from operating instructions, specifications or other special terms of sale;
- (d) Labor charges, loss or damage resulting from improper operation, maintenance or repairs made by person(s) other than Seller or Seller's authorized service station.

In no event shall Seller be liable for any claims whether arising from breach of contract or warranty or claims of negligence or negligent manufacture in excess of the purchase price.

**THIS WARRANTY IS THE SOLE WARRANTY OF SELLERS AND ANY OTHER WARRANTIES, WHETHER EXPRESS OR IMPLIED IN LAW OR IMPLIED IN FACT, INCLUDING ANY WARRANTIES OF MERCHANTABILITY AND FITNESS FOR PARTICULAR USE ARE HEREBY SPECIFICALLY EXCLUDED.**

**LIABILITY LIMITATIONS:** Under no circumstances shall the Seller have any liability for liquidated damages or for collateral, consequential or special damages or for loss of profits, or for actual losses or for loss of production or progress of construction, whether resulting from delays in delivery or performance, breach of warranty, negligent manufacture or otherwise.

**ENVIRONMENTAL AND OSHA REQUIREMENTS:** At the time of shipment of the equipment from the factory, Quincy Compressor / Ortman Fluid Power will comply with the various Federal, State and local laws and regulations concerning occupational health and safety and pollution. However, in the installation and operation of the equipment and other matters over which the seller has no control, the Seller assumes no responsibility for compliance with those laws and regulations, whether by the way of indemnity, warranty or otherwise.

June 30, 2003





Reciprocating / Systems: 217.222.7700  
E-mail: [info@quincycompressor.com](mailto:info@quincycompressor.com)  
Website: [quincycompressor.com](http://quincycompressor.com)

