

User Manual

Nuvair Pro VOC Alarm

Volatile Organic Compound Analyzer



SKU

9651 (handheld version)
9652 (panel mount version)

If you have any questions about this equipment, please contact Nuvair Technical Support at:

Nuvair
1600 Beacon Place
Oxnard, CA 93033 USA

Phone: +1.805.815.4044
Fax: +1.805.486.0900
Email: info@nuvair.com

Hours: Monday through Friday
8:00 AM to 5:00 PM PT



WARNING

This User Manual contains important safety information and should always be available to those personnel operating this equipment. Read, understand, and retain all instructions before operating this equipment to prevent injury or equipment damage.

Every effort was made to ensure the accuracy of the information contained within this manual; however, we retain the right to modify its contents without notice.

Under Nuvair's system of continuous improvement, certain components may be updated or changed as higher quality or more efficient parts and assemblies become available.

Nuvair will make every effort to update manuals as parts and functional aspects change. However, the look or location of components on your product may differ from those in this manual if improvements have been made that do not affect functionality or operational procedures.

Units pictured may also be equipped with different options than those on your product. In this case, the basic operational and maintenance guidelines will still apply.





If you have problems or questions after reading the manual, stop and call Nuvair at +1.805.815.4044 for information.

1. Introduction

This manual will assist you in the proper set-up, operation, and maintenance of the Pro VOC (Volatile Organic Compound) analyzer. Be sure to read the entire manual.

1.1. Symbol Conventions

This manual uses certain words and symbols to call your attention to conditions, practices or techniques that may directly affect your safety. Pay particular attention to information introduced by the following symbols or words:

SYMBOL	MEANING	DESCRIPTION
	DANGER	Indicates an imminently hazardous situation, which if not avoided, will result in serious personal injury or death.
	CAUTION	Indicates a potentially hazardous situation, which if not avoided, could result in serious personal injury or death.
	WARNING	Indicates a potentially hazardous situation, which if not avoided, may result in minor or moderate injury. It may also be used to alert against unsafe practices.
	NOTICE	Notifies people of installation, operation or maintenance information which is important but not hazard related.

2. System Description



WARNING

When using the analyzer for applications with mixed gases other than air, you must first obtain proper instruction from a certified diving instructor with a nationally recognized training agency qualified in mixed gas diving. Improper use of this analyzer may result in incorrect gas analysis which can lead to serious personal injury or death.



WARNING

Although the analyzer is a rugged instrument, careless handling or abuse may result in damage to the analyzer resulting in inaccurate gas analysis. Inaccurate gas analysis can lead to serious personal injury or death.



WARNING

Breathing gas must always be analyzed by two separate analyzers, with one used for gas production and one used for analysis after production. Never depend on a single analyzer during both gas production and delivery. If analyzer readings do not agree, both units must be recalibrated. Inaccurate gas analysis can lead to serious personal injury or death.

The Nuvair Pro VOC Alarm is designed to detect the presence of a volatile organic compound (VOC). It can be connected to a gas compressor for continuous output reading, or it can monitor ambient air (using diffusion mode) and will alert personnel in case of dangerous VOC concentrations in the air.

The Nuvair Pro VOC Alarm is a digital measurement instrument with two visible and audible alarms if VOC value is above or below set values. It is based on a state-of-the-art Photo Ionization Detector (PID) sensor with long-term stability and easy maintenance. It is possible to replace the internal lamp and calibrate the sensor without factory assistance. It is strongly suggested to check the analyzer's alarm function prior any use (bump test¹).

With a resolution of 0.01 ppm (parts per million), the Nuvair Pro VOC Alarm analyzer is designed to measure volatile organic compounds levels directly from pressurized sources or ambient air.

The analyzer comes in either a handheld or panel mount configuration. It is powered by wall plug-in, rechargeable lithium-ion battery, or DIN rail. It includes an internally mounted sensor with audible alarm. The water-resistant case includes a digital display and controls that are environmentally sealed.

The analyzer also has a 4-20 mA analog output for external devices. The analog output can activate an optional relay to automatically shutdown/start-up equipment or sound an external alarm when the analyzer alarm activates.

The analyzer uses a flow adapter cap and flexible tubing to deliver sample gas to the sensor. Pressurized gases must be regulated to avoid damage to the analyzer.

¹ "Bump tests" ensure analyzers go into alarm when sensors are exposed to gases that exceed the analyzer's setpoint. A bump test is not a calibration test, but rather a test to determine if the analyzer will alarm as expected.

2.1. Features

- VOC analysis in gas mix (pressurized or ambient source).
- 0.01 ppm (parts per million) resolution.
- Readings in ppm and mg/m³ (milligram per cubic meter).
- Sensor and analyzer auto-setting.
- Adjustable calibration span value.
- Calibration with certified span gas.
- Calibration of zero with certified 0.0% VOC nitrogen sample gas.
- Two user-customizable audible and visible alarms.
- Full scale measurement range 20 ppm.
- 4-20 mA analog output for external devices.
- Open collector output.
- Actual environmental temperature.
- Numeric display of 50 mm × 35 mm.
- Low battery indicator.
- Powered by a wall plug-in power supply, rechargeable lithium-ion battery, or DIN rail.
- Power consumption 35 mA ca (normal use) – 90 mA ca (in alarm).
- Simple battery and sensor replacement.
- Dimensions: 4-1/8 × 2-1/2 × 1-3/4" (10.5 × 6.2 × 4.4 cm) – Weight 160g (handheld version).

3. Calibration



WARNING

Improper calibration may result in the use of contaminated breathing gas mixtures, which may cause serious injury or death to the person.



WARNING

Calibration or use of the analyzer with a low battery may result in inaccurate readings. Inaccurate gas analysis can lead to serious personal injury or death.



NOTICE

If the analyzer has been subjected to a recent severe change in ambient temperature, allow it to stabilize for 10 minutes before calibration.



WARNING

When analyzer calibration is performed at different atmospheric conditions than the gas being measured, a calibration correction value may be required. Improper calibration may result in the use of incorrect breathing gas mixtures, which may cause serious injury or death to the person using the gas mixture. All the values are calculated assuming gas temperature of 21.11°C (70°F) at 1013 mbar (ambient pressure).

Calibration and/or bump tests should be performed at the same temperature and humidity conditions as the gas being measured. This is not always possible, for example, in a tropical environment where dry breathing gas from a high-pressure scuba cylinder will be measured after analyzer calibration has been performed in the warm, humid ambient air. Under these conditions a calibration correction value may be required, as detailed in the Appendix, or dry air must be used for calibration.



WARNING

Obtain proper training before attempting special calibration procedures. Improper calibration may result in the use of incorrect breathing gas mixtures, which may cause serious injury or death to the person using the gas mixture.

For calibrating the sensor at the Isobutylene span value, connect the sensor to the calibration gas for 2–3 minutes and wait until the reading is stable. Once the reading is stable, press <ON/OFF> and <CALIB> keys simultaneously for a few seconds. Known gas calibration is now complete.

For calibrating the zero, flow pure synthetic air (certified sample gas with 0 PPB VOC content) on the sensor for at least 5 minutes or when the value reading is stable. Once the reading is stable, press <ON/OFF> and <PROG> keys simultaneously for a few seconds. Zero calibration is now complete.

4. Operation

- 4.1. To turn the Pro VOC Alarm on, press the <ON/OFF> key for a few seconds. The unit will power on. The analyzer is powered by a 9-volt battery. It is possible to connect the external power supply of 7–16 VDC. The analyzer can be connected to a gas source or can analyze ambient air.
- 4.2. The main page shows PPM (part per million) of Volatile Organic Compound (VOC) related to Isobutylene in the range 0.01 to 19.99 ppm. Pressing CALIB key it is displayed:
- The Volt output of the battery (BA_T) or the external power supply
 - The Ambient Temperature in °C (TEM)
 - The Sensor mV output (SnS)
 - The Milligram per Cube meter (MGM) of the VOC detected related to Isobutylene.
- 4.3. **PROGRAMMING PAGES.** Pressing the <PROG> key you will go to the programming pages (Pr): Correction Factor (CF), Molecular weight (MoL) Alarm1 (AL1), Alarm2 (AL2), Full scale (FSC), Span Gas Calibration Value (CAL). Press ON/OFF for changing the pages.
- Correction Factor (CF) is the value of the target VOC to be detected related to Isobutylene. Set 1 for isobutylene.
 - Molecular weight (MoL) Is the Molecular weight of the target VOC to be detected.
 - Alarm 1 (AL1) sets the first PPM alarm threshold in PPM.
 - Alarm 2 (AL2) sets the second PPM alarm threshold in PPM.
 - Full scale value (FSC) sets the span output value of the instrument for the 4-20 mA output, if available. The value is related to PPM value that will be displayed at 20mA.
 - Span Gas Calibration Value (CAL) is the value of the span calibration gas generally related to PPM of Isobutylene.
- 4.4. For changing the digit value into any programming page, press <PROG> key.
- 4.5. For going to the next digit value, press <CALIB> key.
- 4.6. For saving the value and going to the next program page, press <ON/OFF> key.
- 4.7. At the end of the programming pages the unit displays <End>.



DANGER

Never expose gas sensors to pressure or you may cause damage and/or false readings. Damaged sensors will not provide accurate gas analysis. Most gas analyzers can be used to analyze a regulated gas sample flow, the contents of a gas cylinder, or the flow from a regulator. The flow rate of gas must equal 1–5 L/min. To produce this flow, a Flow Restrictor and Regulator may be required. A faulty Flow Restrictor can lead to a false analyzer reading. Flow Restrictors should be regularly tested with a Flow Meter. Inaccurate gas analysis can lead to serious personal injury or death.



WARNING

Gas, even under moderate pressures, can cause extreme bodily harm. Never allow any gas stream to be directed at any part of your body.

5. Maintenance

- 5.1. The Pro VOC Alarm warranty is 12 months. Please see Section 10 for full warranty information.
- 5.2. Should you have operational issues at any time, please contact NuVair technical support at +1.805.815.4044 for assistance and trouble shooting.
- 5.3. To clean the Pro VOC Alarm, use a slightly damp soft cloth.
- 5.4. Although designed to be water-resistant, the Pro VOC Alarm should not be intentionally immersed in liquid or left outside unprotected.
- 5.5. The Pro VOC Alarm is built to resist the effects of day-to-day shocks and drops but remember it is a precision analyzer and should be looked after carefully to give long trouble-free service.
- 5.6. Protect the Pro VOC Alarm from long periods of direct sunlight and do not subject it to high or low temperature extremes.
- 5.7. Battery Replacement: To replace the rechargeable Lithium-ion battery:
 1. Remove flow adapter cap.
 2. Remove four screws from analyzer faceplate.
 3. Remove back of case from faceplate.
 4. Disconnect battery connector.
 5. Remove old battery and replace with new battery.
 6. Replace front cover. Make sure not to pinch wires.
 7. Reinstall screws.
 8. Replace flow adapter cap.
 9. Charge battery.
 10. Turn analyzer on.
 11. Check calibration.



NOTICE

Be sure to dispose of spent, leaking, or damaged batteries properly, according to local regulations.

5.8. Sensor Replacement: To replace the VOC sensor:

1. Remove flow adapter cap.
2. Remove four screws from analyzer faceplate.
3. Remove back of case from faceplate.
4. Disconnect sensor electrical connector.
5. Remove old sensor from case by unscrewing.
6. Replace with new sensor.
7. Connect new sensor electrical connector.
8. Replace front cover. Make sure not to pinch wires.
9. Reinstall screws.
10. Replace flow adapter cap.
11. Turn analyzer on.
12. Check calibration.



CAUTION

Be sure to dispose of spent, leaking, or damaged VOC sensors properly, according to local regulations.



DANGER

Do not swallow (ingest) sensor contents or the sensor itself as it may cause severe injury or death. If contents of the sensor or the sensor is swallowed, seek medical attention immediately.

6. Replacement and Optional Parts

The following replacement and optional parts for your Nuair Pro VOC Alarm analyzer are available for purchase at Nuvair.com.

Replacement Sensor: SKU [9512](#)

Handheld Analyzer Watertight Carrying Case: SKU [406UK](#)

SMART START Module for Nuair Pro Alarm Analyzers: SKU [PRO-ALARM-SS-PCB](#)

FAILSAFE Module for Nuair Pro Alarm Analyzers: SKU [SS-PCB-GEN2](#)

Li-ion Battery: SKU [T-800-7.4](#)

Custom International Smart Charger for Li-ion Batteries: SKU [SP-C2S3A](#)

Power Supply for Nuair Pro Alarm Analyzers without Battery: SKU [12-052](#)

Tubing for Nuair Pro Analyzer Flow Adapter Cap: SKU [51075K246](#)

7. Troubleshooting

SYMPTOM	REASON	SOLUTION
Battery symbol	Low Battery	Change the battery
No display	Switched off Bad connection	Switch on Check display connection Check battery connection
Zero reading	Sensor disconnected Sensor expired	Check connection Change sensor
Reading erratic	Pressure on sensor Radio transmission Sensor old or faulty Condensation on sensor.	Check flow Move unit away Change sensor Dry in air
Reading does not change when calibration knob is turned	Faulty connections Sensor failure	Check connections Change sensor
Display segments missing	Display faulty	Return to dealer
Will not calibrate	Sensor faulty Sensor not in air High altitude	Change sensor Check flow adapter Use altitude calibration procedure
Reading drifts	Rapid temperature change	Stabilize temperature & recalibrate

8. Appendix

8.1. VOC Values

See Addendum at the end of this User Manual for a 21-page *Pro VOC Correction Factors* table.

Below are some values of VOC related to isobutylene:

- Isobutylene CF 1
- Alkanes CF 1.2
- Mineral oil CF 0.8
- TAC Total Aromatic Hydrocarbons CF 0.5
- TVOC Total Volatile Organic Compounds CF 1
- Petroleum ether ligroin, VM&P naphtha, benzine CF 0.9
- Hydrogen sulphide CF 4

The molecular weight of the above compounds:

- Isobutylene 56.106 g/mol
- Alkanes from 86 to 142 g/mol (used the average)
- Mineral oil 120 g/mol
- TAC Total Aromatic Hydrocarbons 150-200 g/mol
- TVOC Total Volatile Organic Compounds 100 g/mol
- Petroleum ether ligroin, VM&P naphtha, benzine 125 g/mol
- Hydrogen sulfide 34 g/mol

8.2. 4-20mA Connections (if available)

In the rear of the instrument (if equipped with this feature) there is a jack for the 4-20 mA output. Insert the external signal plug into the jack. For connections refer to the following diagram.

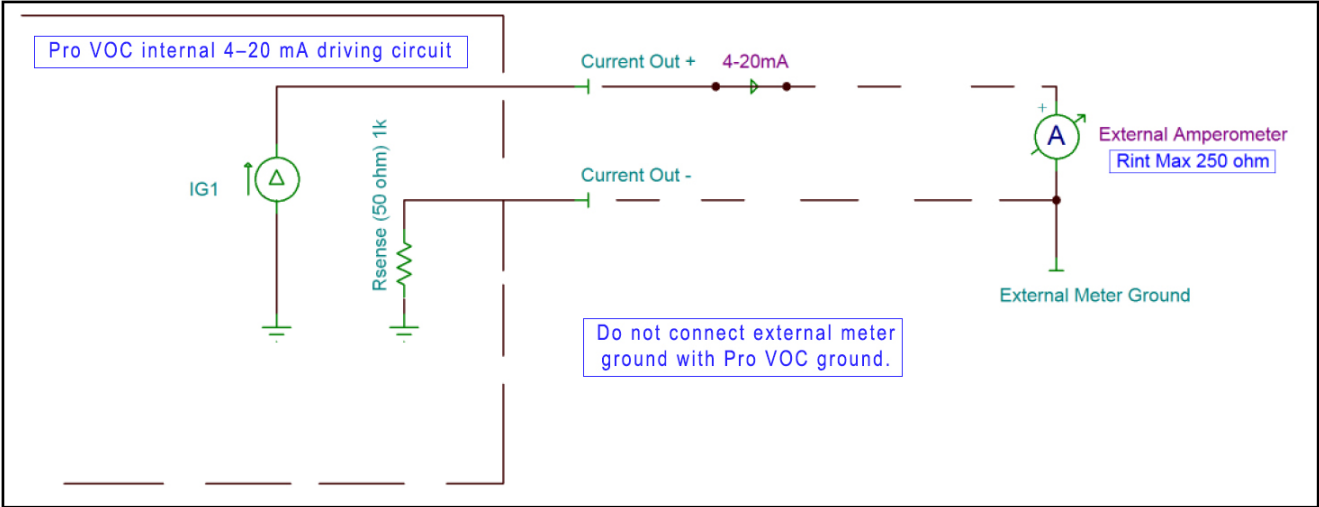

WARNING

The external plug should be connected and disconnected when the analyzer is powered off or the analyzer will power off automatically.

8.3. Open Collector Connections (if available)

In the rear of the analyzer (if equipped with this feature) there is a jack for the Open Collector output. Insert the external signal plug into the jack. For connections, refer to the following diagram.

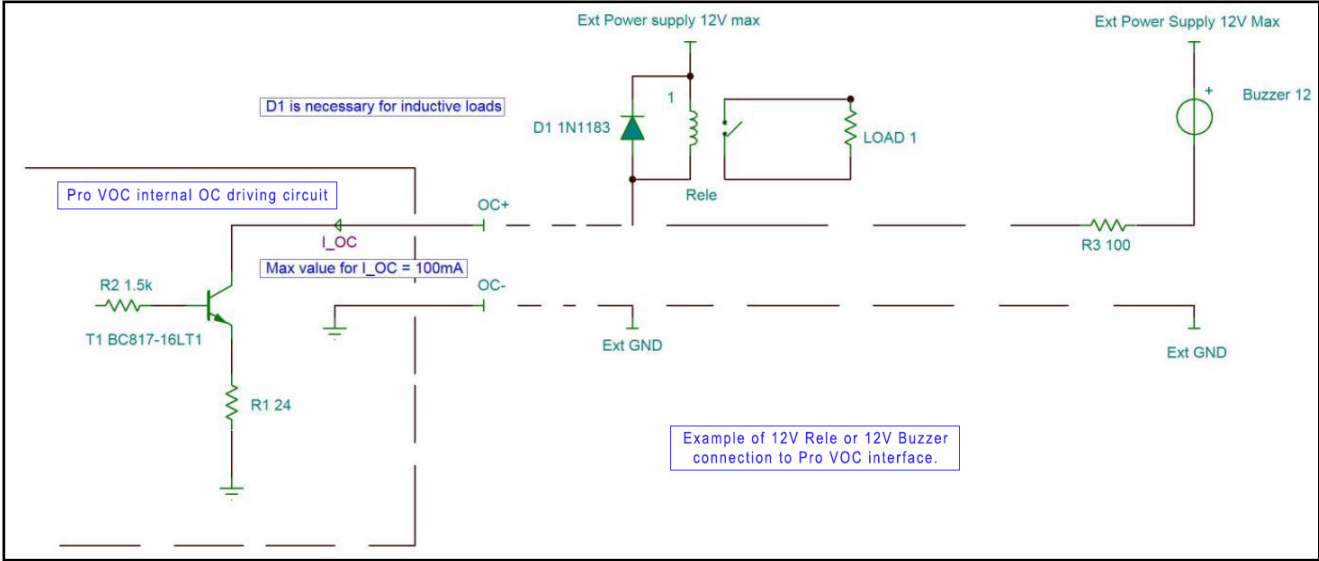

9. Nuvair Pro VOC Alarm Warranty

Nuvair extends a limited warranty, which warrants the Pro VOC Alarm to be free from defects in materials and workmanship under normal use and service for one year (12 months).

The Pro VOC Alarm sensor is warranted according to the pro-rated terms as set forth below. This warranty is non-transferable.

Nuvair will, at its discretion and according to the terms as set forth within, replace or repair any materials which fail under normal use and service and do not exhibit any signs of improper maintenance, misuse, accident, alteration, weather damage, tampering, or use for any other than the intended purpose. Determination of failure is the responsibility of Nuvair, which will work together with the customer to adequately address warranty issues. When any materials are repaired or replaced during the warranty period, they are warranted only for the remainder of the original warranty period. This warranty shall be void and Nuvair shall have no responsibility to repair or replace damaged materials resulting directly or indirectly from the use of repair or replacement parts not approved by Nuvair.

Prorated Terms:

Nuvair warrants the VOC sensor for a period of twelve (12) months from date of purchase. The warranty covers the sensor only.

A warranty registration card, supplied with system documentation, must be filled out and submitted to Nuvair for the warranty to be registered. If the warranty registration card is not received within ten (10) days of purchase, the warranty will begin with the date of manufacture by Nuvair.

Maintenance Items

Any materials which are consumed, or otherwise rendered not warrantable due to processes applied to them, are considered expendable and are not covered under the terms of this policy. This includes the rechargeable battery used in the Pro VOC Alarm.

Return Policy

Application for warranty service can be made by contacting Nuvair during regular business hours and requesting a Return Material Authorization (RMA) number. Materials that are found to be defective must be shipped, freight pre-paid, to the Nuvair office in Oxnard, California (USA). Upon inspection and determination of failure, Nuvair shall exercise its options under the terms of this policy. Warranty serviced materials will be returned to the customer via Nuvair's preferred shipping method, at Nuvair's expense. Any expedited return shipping arrangements to be made at customer's expense must be specified in advance.

Limitation of Warranty and Liability

Repair, replacement, or refund in the manner and within the time provided shall constitute Nuvair's sole liability and the Purchaser's exclusive remedy resulting from any nonconformity or defect. Nuvair shall not in any event be liable for any damages, whether based on contract, warranty, negligence, strict liability or otherwise, including without limitation any consequential, incidental, or special damages, arising with respect to the equipment or its failure to operate, even if Nuvair has been advised of the possibility thereof. Nuvair makes no other warranty or representation of any kind, except that of title, and all other warranties, express or implied, including warranties of merchantability and fitness for a particular purpose, are hereby expressly disclaimed. No salesperson or other representative of Nuvair has authority to make any warranties.

Nuvair Pro VOC Correction Factors

The Nuvair Pro VOC Alarm analyzer sensor is calibrated using isobutylene, but the PID (Photo Ionization Detector) is a broadband VOC detector, with a sensitivity that differs for each VOC. If you know what VOC you are measuring, then the table below will allow you to calculate the concentration for your specific VOC. Remember, these are approximate values, so for best accuracy you should calibrate with the relevant VOC.

The table includes six columns:

- 1 **Gas/VOC** The most common name for the VOC. If you can not find the name of your VOC of concern, please email the Nuvair sales team at info@nuvair.com for assistance.
- 2 **CAS No.** You can find the VOC using the CAS No.: Ask your supplier.
- 3 **Formula** To assist in identifying the VOC.
- 4 **Relative Response/ Correction Factor (CF)** Also called the Response Factor (RF). Multiply the displayed concentration by the Relative Response/ CF/ RF to calculate the actual concentration of the VOC.
- 5 **Relative sensitivity (%)** This is the inverse of the correction factor, specifying the percent response of the VOC, relative to isobutylene. If less than 100%, then the VOC is less responsive than isobutylene; if the relative sensitivity is greater than 100%, then the VOC is more responsive than isobutylene. Relative sensitivity (%) is specified the same way as cross-sensitivity for toxic gas sensors.
- 6 **Minimum Detection Level (MDL)** Also called **Minimum Detectable Quantity (MDQ)**. Typical lowest concentration that can be detected. The PID-AH2 has greater sensitivity than the PID-A12, so the MDL for the PID-AH2 will be much less than the MDL for the PID-A12.

The Relative Response/ CF/ RF is measured in dry air; high humidity will reduce this factor by 30% to 50%, so the CF/ RF should be increased in high humidities.

VOC Response

The PID can not measure all VOCs or gases: two types of VOCs are not measured:

NR: No response. The lamp does not ionize the VOC and the VOC cannot be measured.

NV: The vapor pressure of the VOC at 20°C is less than a few ppm, so this Semi-Volatile Organic Compound (SVOC) cannot be measured.

NA: Not available

Occasionally you will be measuring a mixture of VOCs. If the total concentration is within the linear range of your PID, then it is reasonable to assume that the concentrations are additive without interference between the different VOCs. Remember that if you are measuring a combination of VOCs, then accurate measurement of one of these VOCs will be difficult; without careful data analysis, you will get only a CF averaged measurement*. Be cautious when reporting actual VOC concentration if you know that there may be several VOCs present.

Balance Gas

The relative response is measured in laboratory air, with 20.9% oxygen, balance nitrogen. Some gases absorb UV light without causing any PID response (e.g. methane, ethane). In ambient atmospheres where these gases are present, the measured concentration of target gas will be less than is actually present. Methane absorbs UV strongly, so for accurate measurements in methane containing atmospheres, calibrate with a calibration gas containing the expected methane concentration. 50% LEL methane reduces the reading by up to 50%. Gases such as nitrogen and helium do not absorb UV and do not affect the relative response.

The correction factor for a gas mix containing PID detectable gases A, B, C... with response factors RF(A), RF(B), RF(C), in relative proportions a: b: c... is given by:

$$CF(\text{mix}) = 1 / [(a/CF(A) + b/CF(B) + c/CF(C)...]$$

Accuracy of the Table

This table is for indication only. Table accuracy is 1 to 2 digits only, so when calculating concentration for a specific VOC, specify to 1 or 2 digits only.

Index	Chemical name	Alternative name	Formula	CAS no.	IE, eV	Response Factor (RF)			Typical MDL, 10.6 eV lamp	Typical MDL, 10.6 eV lamp
						10.0 eV	10.6 eV	11.7 eV		
1	Acetaldehyde		C2H4O	75-07-0	10.23	NR	5.5	2.2	25	480
2	Acetamide		C2H5NO	60-35-5	9.69	NA	2	NA		
3	Acetic acid		C2H4O2	64-19-7	10.66	NR	28	4	180	3615
4	Acetic anhydride		C4H6O3	108-24-7	10.14	NA	4	2	20	400
5	Acetoin	3-hydroxybutanone	C4H8O2	513-86-0	~9.8	NA	1	NA		
6	Acetone	2-propanone	C3H6O	67-64-1	9.69	1.2	1.17	1.7	5	70
7	Acetone cyanohydrin		C4H7NO	75-86-5	11.09	NR	NR	1		
8	Acetonitrile		CH3CN	75-05-8	12.20	NR	NR	100		
9	Acetophenone	methyl phenyl ketone	C8H8O	98-86-2	9.29	NA	0.6	NA		
10	Acetyl bromide		C2H3BrO	506-96-7	10.24	NR	8	1.5		
11	Acetylene	ethyne	C2H2	74-86-2	11.40	NR	NR	2		
12	Acetylglycine, N-		C4H7NO3	543-24-8	9.40	NA	2	NA		
13	Acrolein	Prop-2-enal	C3H4O	107-02-8	10.22	NA	3.2	1.2	20	400
14	Acrylic Acid		C3H4O2	79-10-7	10.60	NR	21	3	15	275
15	Acrylonitrile		C3H3N	107-13-1	10.91	NR	NR	1.6		
16	Alkanes, n-, C6+		CnH2n+2	N/A	~10	NA	1.2	NA		
17	Allyl acetoacetate		C7H10O3	1118-84-9	~10	NR	1.5	NA		
18	Allyl alcohol		C3H6O	107-18-6	9.63	4	2.3	1.1	10	200
19	Allyl bromide	3-bromopropene	C3H5Br	106-95-6	9.96	NA	3	NA		
20	Allyl chloride	3-chloropropene	C3H5Cl	107-05-1	10.05	NA	4.5	0.7	20	450
21	Allyl glycidyl ether		C6H10O2	106-92-3	~10	NA	0.8	NA		
22	Allyl propyl disulfide		C6H12S2	2179-59-1	~8.5	NA	0.4	NA		
23	Ammonia		NH3	7664-41-7	10.18	NA	8.5	5.7	40	850
24	Amyl acetate		C7H14O2	628-63-7	9.90	9	1.8	0.64	10	180
25	Amyl alcohol		C5H12O	71-41-0	10.00	10	2.6	0.75	15	320
26	Amyl alcohol, tert-		C5H12O	75-85-4	9.80	2.8	1.5	1.01		
27	Anethole		C10H12O	104-46-1	~9	NA	0.4	NA		
28	Aniline		C6H7N	62-53-3	7.70	0.8	0.5	NA	3	50
29	Anisole		C7H8O	100-66-3	8.21	0.59	0.59	0.57	2	50
30	Anisyl aldehyde		C8H8O2	123-11-5	~9	NA	0.4	NA		
31	Argon		Ar	7440-37-1	15.76	NA	NR	NR		
32	Arsine		AsH3	7784-42-1	9.89	NA	2.5	3	15	250
33	Asphalt, petroleum fumes			8052-42-4	~9	NA	1	NA	5	100
34	Benzaldehyde		C7H6O	100-52-7	9.49	0.9	0.7	0.9	5	85
35	Benzene		C6H6	71-43-2	9.24	0.54	0.5	0.53	3	50
36	Benzene thiol	thiophenol	C6H5SH	108-98-5	8.32	0.8	0.7	NA	4	70
37	Benzoic acid		C7H6O2	65-85-0	9.30	NA	0.7	NA		
38	Benzonitrile	cyanobenzene	C7H5N	100-47-0	9.62	0.8	0.7	2	4	70
39	Benzoquinone, o-		C6H4O2	583-63-1	9.30	NA	1	NA		
40	Benzoquinone, p-		C6H4O2	106-51-4	10.01	NA	1	NA		
41	Benzoyl bromide		C7H5BrO	618-32-6	9.65	NA	2	NA		
42	Benzyl 2-phenylacetate		C15H14O2	102-16-9	~9	NA	0.5	NA		
43	Benzyl acetate		C9H10O2	140-11-4	~9	NA	0.6	NA		
44	Benzyl alcohol		C7H8O	100-51-6	8.26	1.6	1	1.3	6	125

Index	Chemical name	Alternative name	Formula	CAS no.	IE, eV	Response Factor (RF)			Typical MDL, 10.6 eV lamp	Typical MDL, 10.6 eV lamp
						10.0 eV	10.6 eV	11.7 eV		
45	Benzyl chloride		C7H7Cl	100-44-7	9.14	0.7	0.7	0.58	3	55
46	Benzyl-2-(dimethylamino)-4'-morpholinobutyrophenone, 2-	IHT-PI 910, Irgacure 369, Lancure369	C23H30N2O2	119313-12-1		NV	NV	NV		
47	Benzyl formate		C8H8O2	104-57-4	9.32	NA	0.8	0.66	5	77
48	Benzyl isobutyrate		C11H14O2	103-28-6	~9	NA	0.5	NA		
49	Benzyl nitrile		C8H7N	140-29-4	9.39	NA	1	NA		
50	Benzylamine		C7H9N	100-46-9	7.56	NA	0.6	NA		
51	Biphenyl		C12H10	92-52-4	8.23	0.6	0.4	NA	2	40
52	Bisphenol A diglycidyl diacrylate	Bisphenol A-epichlorohydrin acrylate, (C15H16O2)x.(C3H5ClO)x.x(C3H4O2)		55818-57-0		NA	NA	NA		
53	Borneol		C10H18O	507-70-0	~9	NA	0.8	NA		
54	Boron trifluoride		BF3	7637-07-2	15.50	NR	NR	NR		
55	Bromine		Br2	7726-95-6	10.55	NR	15	0.74	100	2000
56	Bromine pentafluoride		BrF5	7789-30-2	13.17	NR	NR	NR		
57	Bromo-2,2-dimethylpropane, 1-	neopentyl bromide	C5H11Br	630-17-1	10.04	NA	2	NA		
58	Bromo-2-chloroethane, 1-		C2H4BrCl	107-04-0	10.57	NR	3	0.44		
59	Bromo-2-methylpentane, 1-		C6H13Br	25346-33-2	10.09	NA	2	NA		
60	Bromoacetone		C3H5BrO	598-31-2	9.73	NA	1	NA		
61	Bromoacetylene		C2HBr	593-61-3	10.31	NR	4	NA		
62	Bromobenzene		C6H5Br	108-86-1	8.98	0.32	0.32	0.34	4	70
63	Bromobutane, 1-		C4H9Br	109-65-9	10.13	14	1.6	0.6		
64	Bromobutane, 2-		C4H9Br	78-76-2	10.01	1.6	0.97	0.62		
65	Bromochloromethane		CH2ClBr	74-97-5	10.77	NR	NR	NA		
66	Bromocyclohexane		C6H11Br	108-85-0	9.87	NA	2	NA		
67	Bromoethane		C2H5Br	74-96-4	10.29	NR	1.6	0.79	25	500
68	Bromoethanol, 2-		C2H5BrO	540-51-2	10.00	NA	2	NA		
69	Bromoethyl methyl ether, 2-		C3H7OBr	6482-24-2	10.00	NA	2.5	2	15	250
70	Bromofluoromethane		CH2FBr	373-52-4	~11	NR	NR	NA		
71	Bromoform	tribromomethane	CHBr3	75-25-2	10.48	NR	2.8	0.5	15	280
72	Bromopentane, 1-	n-pentyl bromide	C5H11Br	110-53-2	10.10	3.5	1.1	0.47		
73	Bromopropane, 1-	n-propyl bromide	C3H7Br	106-94-5	10.18	70	1.5	0.7	7	130
74	Bromopyridine, 3-		C5H4BrN	625-55-1	9.75	NA	2	NA		
75	Bromopyridine, 4-		C5H4BrN	1120-87-2	9.94	NA	2	NA		
76	Bromotrifluoromethane		CF3Br	75-63-8	11.78	NR	NR	NA		
77	Bromotrimethylsilane		C3H9BrSi	2857-97-8	10.00	NA	2	NA		
78	But-2-ynal		C4H4O	1119-19-3	10.20	NA	3	NA		
79	But-3-ynal		C4H4O	52844-23-2	9.85	NA	1.5	NA		
80	Butadiene diepoxide, 1,3-		C4H6O2	1464-53-5	10.00	NA	4	1.2	20	400
81	Butadiene, 1,3-		C4H6	106-99-0	9.07	0.8	0.8	1.1	4	80
82	Butane, n-		C4H10	106-97-8	10.63	NR	40	1.5	230	4600
83	Butanedione, 2,3-	biacetyl, diacetyl	C4H6O2	431-03-8	9.56	0.87	0.84	1		
84	Butanoic acid		C4H8O2	107-92-6	10.17	NA	5	NA		
85	Butanol, 1-		C4H10O	71-36-3	10.04	25	3.9	1	20	400
86	Butanol, 2-		C4H10O	78-92-2	10.10	8	3	1.2		
87	Buten-3-ol, 1-		C4H8O	598-32-3	9.50	3	1.8	1.3	6	115
88	Butene nitrile, 3-		C4H5N	109-75-1	10.20	NA	~3	NA		
89	Butene, 1-		C4H8	106-98-9	9.58	NA	1.5	NA	7	130
90	Butene, 2-		C4H8	107-01-7	9.10	NA	1.3	NA		

Index	Chemical name	Alternative name	Formula	CAS no.	IE, eV	Response Factor (RF)			Typical MDL, 10.6 eV lamp	Typical MDL, 10.6 eV lamp
						10.0 eV	10.6 eV	11.7 eV		
91	Butene, cis-2-		C4H8	590-18-1	9.13	NA	1.3	NA		
92	Butene, trans-2-		C4H8	624-64-6	9.13	NA	1.3	NA		
93	Butenoic acid, 3-		C4H6O2	107-93-7	9.75	NA	2	NA		
94	Butoxyethanol, 2-	Butyl Cellosolve®	C6H14O2	111-76-2	8.68	NA	1.1	0.62	6	110
95	butoxyethoxyethanol	ethylene glycol monobutyl ether acetate	C8H18O3	112-34-5	~9	NA	1	NA		
96	Butoxyethylacetate, 2-		C8H16O3	112-07-2	~9.8	NA	3	NA		
97	Butyl acetate		C6H12O2	123-86-4	9.91	12	2.5	0.8	10	240
98	Butyl acetate, sec-		C6H12O2	105-46-4	9.91	5.5	1.8	0.8		
99	Butyl acetate, tert-		C6H12O2	540-88-5	~9.7	1.65	1.05	0.83		
100	Butyl acrylate		C7H12O2	141-32-2	~9.6	NA	1.5	0.6	8	150
101	Butyl butyrate		C8H16O2	109-21-7	~9.7	NA	1.8	NA		
102	Butyl chloride	chlorobutane	C4H9Cl	109-69-3	10.67	NR	NR	1.5		
103	Butyl chloroformate		C5H9ClO2	592-34-7	~10.4	NR	3.2	NA		
104	Butyl cyclohexan-1-ol, 4- tert-	4-t-butylcyclohexanol	C10H20O	98-52-2	~8.8	NA	1.4	NA		
105	Butyl cyclohexyl acetate, 2- tert-	2-t-butylcyclohexylacetate	C12H22O2	88-41-5	~10	NA	0.9	NA		
106	Butyl ether, n-	dibutyl ether	C8H18O	142-96-1	9.28	1.1	0.82	0.42		
107	Butyl glycidyl ether		C7H14O2	2426-08-6	~10	NA	2	NA		
108	Butyl iodide	iodobutane	C4H9I	542-69-8	9.23	NA	1	NA		
109	Butyl isocyanate		C5H9NO	111-36-4	10.14	NA	2.5	NA		
110	Butyl lactate		C7H14O3	138-22-7	9.80	NA	2.5	NA	15	250
111	Butyl mercaptan, n-	n-butyl mercaptan	C4H10S	109-79-5	9.15	NA	0.5	2	3	50
112	Butyl mercaptan, tert-		C4H10S	75-66-1	9.03	NA	0.4	NA		
113	Butyl methacrylate		C8H14O2	97-88-1	~9.5	NA	1	NA		
114	Butyl propionate, n-		C7H14O2	590-01-2	~9.7	4	1.9	0.8		
115	Butylamine, n-		C4H11N	109-73-9	8.71	NA	1	0.7	5	100
116	Butylamine, sec-		C4H11N	513-49-5	8.70	NA	0.9	NA	5	90
117	Butylamine, tert-		C4H11N	75-64-9	8.64	1.5	1.2	1.1		
118	Butylbenzene		C10H14	104-51-8	8.69	0.45	0.5	NA		
119	Butylbenzene, sec-		C10H14	135-98-8	8.68	0.4	0.4	NA		
120	Butylbenzene, tert-		C10H14	98-06-6	8.69	0.4	0.4	NA		
121	Butylene carbonate, 1,2-	4-ethyl-1,3-dioxolan-2-one	C5H8O3	4437-85-8	~10.4	NR	18	3.8		
122	Butylphenol, o-sec-		C10H14O	89-72-5	7.80	NA	0.9	NA		
123	Butyn-1-ol, 2-		C4H6O	764-01-2	9.78	NA	1.5	NA		
124	Butyn-2-one		C4H4O	1423-60-5	10.17	NA	3	NA		
125	Butyraldehyde		C4H8O	123-72-8	9.86	1.9	1.7	1.2		
126	Butyrolactone, gamma-		C4H6O2	96-48-0	10.26	NA	15	NA		
127	Butyronitrile		C4H7N	109-74-0	11.67	NR	NR	2		
128	Butyryl chloride		C4H7ClO	141-75-3	~10.4	NR	3	NA		
129	Camphene		C10H16	565-00-4	8.86	0.4	0.5	NA	2	45
130	Camphor		C10H16O	76-22-2	8.76	NA	0.4	NA		
131	Carbon dioxide		CO2	124-38-9	13.77	NR	NR	NR	0	0
132	Carbon disulfide		CS2	75-15-0	10.08	1.3	1.4	0.3	7	140
133	Carbon monoxide		CO	630-08-0	14.01	NR	NR	NR	0	0
134	Carbon suboxide		C3O2	504-64-3	10.60	NR	10	NA		
135	Carbon tetrabromide	tetrabromomethane	CBR4	558-13-4	10.31	NR	3	NA	15	300
136	Carbon tetrachloride	R-10, tetrachloromethane	CCl4	56-23-5	11.47	NR	NR	1.7		
137	Carbonyl fluoride		COF2	353-50-4	13.02	NR	NR	NR		
138	Carbonyl sulfide		COS	463-58-1	11.18	NR	NR	0.4		

Index	Chemical name	Alternative name	Formula	CAS no.	IE, eV	Response Factor (RF)			Typical MDL, 10.6 eV lamp	Typical MDL, 10.6 eV lamp
						10.0 eV	10.6 eV	11.7 eV		
139	Carene		C10H16	13466-78-9	8.40	NA	0.5	NA		
140	Carvacrol		C10H14O	499-75-2	~9	NA	0.8	NA		
141	Carvone, R-		C10H14O	6485-40-1	9.77	1.5	1.6	1.7	5	100
142	Caryophyllene		C15H24	13877-93-5	~9	NA	0.4	NA		
143	Chloramine	monochloramine	ClH2N	10599-90-3	9.85	NA	2	NA		
144	Chlorine		Cl2	7782-50-5	11.48	NR	NR	1		
145	Chlorine dioxide		ClO2	10049-04-4	10.36	NR	NR	NR	5	100
146	Chlorine trifluoride		ClF3	7790-91-2	12.65	NR	NR	NA		
147	Chloro-1,1,1,2-tetrafluoroethane, 2-	R-124	C2HClF4	2837-89-0	~12	NR	NR	NR		
148	Chloro-1,1,1-trifluoroethane, 2-	R-133a	C2H2ClF3	75-88-7	~12	NR	NR	NR		
149	Chloro-1,1,2,2-tetrafluoroethane, 1-	R-124a	C2HClF4	354-25-6	~12	NR	NR	NR		
150	Chloro-1,1,2-trifluoroethane, 1-	R-133b	C2H2ClF3	421-04-5	~12	NR	NR	NR		
151	Chloro-1,1-difluoroethane, 1-	R-142b	C2H3ClF2	75-68-3	11.98	NR	NR	NR		
152	Chloro-1,1-difluoroethane, 2-	R-142	C2H3ClF2	338-65-8	~11.9	NR	NR	NR		
153	Chloro-1,1-difluoroethene, 2-	R-1122	C2HClF2	359-10-4	9.80	NA	1.5	NA		
154	Chloro-1,2,2-trifluoroethane, 1-	R-133	C2H2ClF3	431-07-2	~12	NR	NR	NR		
155	Chloro-1-fluoroethane, 1-	R-151a	C2H4ClF	1615-75-4	~11.7	NR	NR	1		
156	Chloro-2-fluoroethane, 1-	R-151	C2H4ClF	762-50-5	~11.7	NR	NR	1		
157	Chloro-2-propanone, 1-		C3H5ClO	78-95-5	9.92	NA	1	NA		
158	Chloroacetaldehyde	2-chloroethanal	C2H3OCl	107-20-0	10.16	NA	3	NA		
159	Chlorobenzene		C6H5Cl	108-90-7	9.07	0.5	0.45	0.47	2	50
160	Chlorobutane, 1-		C4H9Cl	109-69-3	10.64	NR	10	0.74		
161	Chlorobutane, 2-		C4H9Cl	78-86-4	10.57	NR	5.8	1		
162	Chlorocyclohexane		C6H11Cl	542-18-7	10.10	20	2	0.5		
163	Chlorodifluoromethane		CHClF2	75-45-6	12.45	NR	NR	NR		
164	Chloroethane		C2H5Cl	75-00-3	10.97	NR	NR	1.1		
165	Chloroethanol, 2-	ethylene chlorohydrin	C2H5ClO	107-07-3	10.50	NR	10	1	50	1000
166	Chloroethyl methyl ether, 2-		C3H7ClO	627-42-9	10.25	NA	2.6	NA	13	250
167	Chlorofluoromethane		CH2ClF	593-70-4	11.71	NR	NR	NA		
168	Chloroform		CHCl3	67-66-3	11.42	NR	NR	3.5		
169	Chloromethane		CH3Cl	74-87-3	11.28	NR	NR	0.74		
170	Chloromethoxyethane	chloromethyl ethyl ether	C3H7ClO	3188-13-4	10.30	NR	4	NA		
171	Chloropentafluoroethane		C2ClF5	76-15-3	12.96	NR	NR	NR		
172	Chloroprene	2-chlorobuta-1,3-diene	C4H5Cl	126-99-8	8.79	NA	1.3	NA	16	320
173	Chloropyridine, 2-		C5H4ClN	109-09-1	9.00	NA	1	NA		
174	Chlorostyrene, o-		C8H7Cl	2039-87-4	~8.5	NA	0.4	NA		
175	Chlorotoluene, m-	Chlorotoluene, 3-	C7H7Cl	108-41-8	8.70	NA	0.5	NA	3	50
176	Chlorotoluene, o-	Chlorotoluene, 2-	C7H7Cl	95-49-8	8.83	NA	0.5	0.6	2	50
177	Chlorotoluene, p-	Chlorotoluene, 4-	C7H7Cl	106-43-4	8.69	0.3	0.4	0.2377		
178	Chlorotrifluoroethylene	R-1113	C2ClF3	79-38-9	9.81	NA	1	1	5	100
179	Chlorotrifluoromethane		CClF3	75-72-9	12.60	NR	NR	NA		
180	Cinnamic aldehyde		C8H8O	104-55-2	~9	NA	0.4	NA		
181	Cinnamyl acetate		C11H12O2	21040-45-9	~9	NA	0.4	NA		
182	Cinnamyl alcohol		C9H10O	104-54-1	8.10	NA	0.4	NA		
183	Citral		C10H16O	5392-40-5	~8.7	3.4	1.7	1.7	5	100
184	Citronellal		C10H18O	106-23-0	~9	NA	0.9	NA		
185	Citronellol		C10H20O	26489-01-0	~8.5	NA	1	NA	5	100

Index	Chemical name	Alternative name	Formula	CAS no.	IE, eV	Response Factor (RF)			Typical MDL, 10.6 eV lamp	Typical MDL, 10.6 eV lamp
						10.0 eV	10.6 eV	11.7 eV		
186	Citronellol acetate		C12H22O2	150-84-5	~9	NA	1.5	NA		
187	Citronellol formate		C11H20O2	105-85-1	~9	NA	1.5	NA		
188	Citronellyl isobutyrate		C14H26O2	97-89-2	~9	NA	0.9	NA		
189	Coumarin		C9H6O2	91-64-5	~9	NA	0.4	NA		
190	Creosote		n/a	8021-39-4	~9	NA	1	NA		
191	Cresol, m-	3-methylphenol	C7H8O	108-39-4	8.36	1.5	2.2	0.8	5	105
192	Cresol, o-	2-methylphenol	C7H8O	95-48-7	8.14	1.5	1.1	NA	5	105
193	Cresol, p-	4-methylphenol	C7H8O	106-44-5	8.31	1.5	1.1	NA	5	105
194	Cresyl acetate, p-		C9H10O2	140-39-6	8.60	NA	1	NA		
195	Cresyl ethyl ether, p-		C9H12O	622-60-6	~9	NA	0.8	NA		
196	Cresyl methyl ether		C8H10O	104-93-8	~9	NA	0.8	NA		
197	Crotonaldehyde		C4H6O	4170-30-3	9.73	NA	1	1	5	100
198	Crotonyl alcohol		C4H8O	6117-91-5	9.13	NA	0.8	NA		
199	Cyanamide		CH2N2	420-04-2	10.40	NA	NR	NA		
200	Cyanogen bromide		CNBr	506-68-3	11.84	NR	NR	NR		
201	Cyanogen chloride		CNCl	506-77-4	12.49	NR	NR	NR		
202	Cycloalkanes		N/A	N/A	~10	NA	1.5	NA		
203	Cyclobutanone		C4H6O	1191-95-3	9.35	NA	1.2	NA		
204	Cyclobutene		C4H6	822-35-5	9.43	NA	3	NA		
205	Cycloheptane		C7H14	291-64-5	9.82	NA	1.1	NA		
206	Cyclohex-2-enedione, 1,4-		C6H6O2	4505-38-8	9.77	NA	1	NA		
207	Cyclohexane		C6H12	110-82-7	9.98	3.3	1.3	0.64	7	130
208	Cyclohexanethiol		C6H12S	1569-69-3	~9	NA	0.5	NA		
209	Cyclohexanol		C6H12O	108-93-0	10.00	2.7	1.6	0.9	15	300
210	Cyclohexanone		C6H10O	108-94-1	9.16	1.2	1	0.8	6	110
211	Cyclohexene		C6H10	110-83-8	8.95	1.4	0.9	0.56	5	75
212	Cyclohexyl acetate		C8H14O2	622-45-7	~9.5	NA	1.2	NA		
213	Cyclohexylamine		C6H13N	108-91-8	8.37	0.9	1	1	5	100
214	Cyclooctadiene		C8H12	29965-97-7	~9.5	NA	1	NA		
215	Cyclopentadiene		C5H6	542-92-7	8.56	NA	0.8	NA		
216	Cyclopentane		C5H10	287-92-3	10.52	NA	10	0.7	20	400
217	Cyclopentanone		C5H8O	120-92-3	9.26	1	0.9	0.8		
218	Cyclopentene		C5H8	142-29-0	9.01	140	1.5	NA		
219	Cyclopentene-1,3-dione, 4-		C5H4O2	930-60-9	9.60	NA	1	NA		
220	Cyclopropylamine		C3H7N	765-30-0	8.80	1.7	1.5	1.1		
221	Cymene, p-	4-isopropyltoluene	C10H14	99-87-6	8.29	NA	0.4	NA		
222	Decahydronaphthalene	decalin	C10H18	91-17-8	9.14	NA	0.9	NA		
223	Decanal		C10H20O	112-31-2	~9	NA	0.9	NA		
224	Decane, n-		C10H22	124-18-5	9.65	4.2	1.2	0.37	5	100
225	Decanol		C10H22O	112-30-1		NA	1.2	NA		
226	Decyne, 1-		C10H18	764-93-2	9.91	0.83	0.43	0.37		
227	Desfluorane	2-(difluoromethoxy)-1,1,1,2-tetrafluoroethane	C3H2F6O	57041-67-5	~11	NR	NR	2		
228	Deuterium oxide		D2O	7789-20-0	13.60	NR	NR	NR		
229	Diacetone alcohol	4-hydroxy-4-methyl-pentan-2-one	C6H12O2	123-42-2	~9.6	0.84	0.9	1.2	5	80
230	Diazine, 1,2-	1,2-diazabenzene	C4H4N2	289-80-5	9.65	NA	3	NA		
231	Diazine, 1,3-	1,3-diazabenzene	C4H4N2	289-95-2	9.33	NA	3	NA		
232	Dibenzoyl peroxide		C14H10O4	94-36-0		NA	0.8	NA	5	80

Index	Chemical name	Alternative name	Formula	CAS no.	IE, eV	Response Factor (RF)			Typical MDL, 10.6 eV lamp	Typical MDL, 10.6 eV lamp
						10.0 eV	10.6 eV	11.7 eV		
233	Diborane		B ₂ H ₆	19287-45-7	11.38	NR	NR	NA		
234	Dibromoacetylene		C ₂ Br ₂	624-61-3	9.65	NA	2	NA		
235	Dibromochloromethane		CHBr ₂ Cl	124-48-1	10.59	NR	10	0.7	50	1000
236	Dibromocyclohexane, 1,2-		C ₆ H ₁₀ Br ₂	5401-62-7	10.02	NA	3	NA		
237	Dibromocyclopentane		C ₅ H ₈ Br ₂	33547-17-0	10.06	NA	3	NA		
238	Dibromodichloromethane		CBr ₂ Cl ₂	594-18-3	10.40	NR	4	NA		
239	Dibromodifluoromethane		CF ₂ Br ₂	75-61-6	11.07	NR	NR	NA		
240	Dibromoethane, 1,2-	EDB, ethylene dibromide	C ₂ H ₄ Br ₂	106-93-4	10.35	NR	2	0.6	10	200
241	Dibromoethene, 1,1-	vinylidene bromide	C ₂ H ₂ Br ₂	593-92-0	9.78	NA	1.5	NA		
242	Dibromoethene, 1,2-		C ₂ H ₂ Br ₂	540-49-8	9.63	NA	1.5	NA		
243	Dibromomethane	methylene dibromide	CH ₂ Br ₂	74-95-3	10.41	NR	1.9	0.7		
244	Dibromotetrafluoroethane, 1,2-		C ₂ F ₄ Br ₂	124-73-2	11.1	NR	NR	NA		
245	Dibutyl hydrogen phosphate	Dibutyl hydrogen phosphate	HC ₈ H ₁₈ PO ₄	107-66-4		NA	4	NA	20	400
246	Dichloro-1,1,1-trifluoroethane, 2,2- R-124		C ₂ HCl ₂ F ₃	306-83-2	11.50	NR	NR	NA		
247	Dichloro-1,1-difluoroethane, 1,2-	R-132b	C ₂ H ₂ F ₂ Cl ₂	1649-08-7	~11.5	NR	NR	1		
248	Dichloro-1,2,2-trifluoroethane, 1,2-	R-123a	C ₂ HCl ₂ F ₃	354-23-4	~11.5	NR	NR	NA		
249	Dichloro-1,2-difluoroethane, 1,2-		C ₂ H ₂ Cl ₂ F ₂	431-06-1		NA	NR	NA		
250	Dichlorodifluoroethane	R-132	C ₂ H ₂ F ₂ Cl ₂	25915-78-0		NA	NR	NA		
251	Dichloro-2,2-difluoroethane, 1,1-	R-132a	C ₂ H ₂ F ₂ Cl ₂	471-43-2	~11.5	NR	NR	1		
252	Dichloro-1,1-difluoroethane, 1,2-	R-132b	C ₂ H ₂ F ₂ Cl ₂	1649-08-7	11.80	NA	NA	NA		
253	Dichloro-1,2-difluoroethane, 1,1-	R-132c	C ₂ H ₂ F ₂ Cl ₂	1842-05-3		NA	NA	NA		
254	Dichloro-1,2-difluoroethene, 1,2- (cis)		C ₂ Cl ₂ F ₂	598-88-9	10.20	NA	2	NA		
255	Dichloro-1-fluoroethane, 1,1-	R-141b	C ₂ H ₃ FCl ₂	1717-00-6	~11	NR	NR	1		
256	Dichloro-1-fluoroethane, 1,2-	R-141	C ₂ H ₃ FCl ₂	430-57-9	~11	NR	NR	1		
257	Dichloro-1-propene, 2,3-		C ₃ H ₄ Cl ₂	78-88-6	~10.5	NR	1.4	0.7	7	140
258	Dichloro-2,2,-difluoroethene, 1,1-	R-1112a	C ₂ Cl ₂ F ₂	79-35-6	9.69	NA	1	1		
259	Dichloroacetylene		C ₂ Cl ₂	7572-29-4	9.90	NA	5	NA	25	500
260	Dichlorobenzene, o-		C ₆ H ₄ Cl ₂	95-50-1	9.06	0.5	0.5	0.38	3	50
261	Dichlorobenzene, p-		C ₆ H ₄ Cl ₂	106-46-7	9.06	0.5	0.5	0.38		
262	Dichlorodifluoromethane		CCl ₂ F ₂	75-71-8	11.75	NR	NR	NR		
263	Dichloroethane, 1,1-	1,1-DCA	C ₂ H ₄ Cl ₂	75-34-3	11.06	NR	NR	2		
264	Dichloroethane, 1,2-	EDC or 1,2-DCA	C ₂ H ₄ Cl ₂	107-06-2	11.05	NR	NR	0.6		
265	Dichloroethene, 1,1-	1,2-dichloroethene	C ₂ H ₂ Cl ₂	75-35-4	10.00	NA	1	1	5	100
266	Dichloroethene, 1,2-	1,1-DCE, vinylidene chloride	C ₂ H ₂ Cl ₂	540-59-0	9.65	0.29	0.4	0.34	4	70
267	Dichloroethene, cis-1,2-	c-1,2-DCE	C ₂ H ₂ Cl ₂	156-59-2	9.66	NA	0.8	1	4	80
268	Dichloroethene, trans-1,2-	t-1,2-DCE	C ₂ H ₂ Cl ₂	156-60-5	9.65	NA	0.4	0.34		
269	Dichlorofluoromethane		CHFCl ₂	75-43-4	12.39	NR	NR	NR		
270	Dichloromethane	methylene chloride	CH ₂ Cl ₂	75-09-2	11.32	NR	70	1	200	3900
271	Dichloromethylamine		CH ₃ Cl ₂ N	7651-91-4	9.52	NA	2	NA		
272	Dichloropropane, 1,2-		C ₃ H ₆ Cl ₂	78-87-5	10.87	NR	NR	0.7		
273	Dichlorotetrafluoroethane, 1,1-		C ₂ Cl ₂ F ₄	374-07-2	12.2	NR	NR	NR		
274	Dichlorotetrafluoroethane, 1,2-		C ₂ Cl ₂ F ₄	76-14-2	12.20	NR	NR	NR		
275	Dicyclohexylamine		C ₁₂ H ₂₃ N	101-83-7	~8.5	NA	0.9	NA		
276	Dicyclopentadiene		C ₁₀ H ₁₂	77-73-6	7.74	NA	0.9	1	5	90
277	Diesel fuel			68334-30-5	8	NA	0.8	0.4	4	75

Index	Chemical name	Alternative name	Formula	CAS no.	IE, eV	Response Factor (RF)			Typical MDL, 10.6 eV lamp	Typical MDL, 10.6 eV lamp
						10.0 eV	10.6 eV	11.7 eV		
278	Diethoxyethane, 1,1-		C6H14O2	105-57-7	9.78	1	1.5	0.6		
279	Diethyl carbonate		C5H10O3	105-58-8	~10.3	NR	7	1.2		
280	Diethyl ether	ethyl ether	C4H10O	60-29-7	9.53	NA	1.1	1.9	4	90
281	Diethyl maleate		C8H12O4	141-05-9	~10	NA	2	NA	10	200
282	Diethyl malonate		C7H12O4	105-53-3	10.20	NR	4	NA		
283	Diethyl phosphite		C4H11O3P	762-04-9	10.31	NR	2	NA		
284	Diethyl phthalate		C12H14O4	84-66-2	~9	NA	1	NA	5	100
285	Diethyl sulfate		C4H10SO4	64-67-5	~10.5	NR	3	NA	15	300
286	Diethyl sulfide		C4H10S	352-93-2	8.43	0.5	0.6	1	3	50
287	Diethyl sulfone		C4H10O2S	597-35-3	9.96	NA	2	NA		
288	Diethylacetylene		C6H10	928-49-4	10.03	NA	2	NA		
289	Diethylamine		C4H11N	109-89-7	8.01	0.8	1.4	0.6	5	100
290	Diethylaminoethanol, 2-		C6H15ON	100-37-8	8.58	NA	2.7	NA	15	270
291	Diethylaminopropylamine, 3-		C7H18N2	104-78-9	~9	3	5	3	5	100
292	Diethylene glycol monoethyl ether		C6H14O3	111-90-1	~9	NA	0.6	NA		
293	Diethylenetriamine	iminodi(ethylamine) 2,2-	C4H13N3	111-40-0	~9	NA	1	NA	5	90
294	Diethylhydroxylamine		C4H11NO	3710-84-7	~10	1.5	1.5	1.2		
295	Diethylsilane		C4H12Si	542-91-6	9.80	NA	2	NA		
296	Difluoroethane, 1,1-		C2H4F2	75-37-6	11.87	NR	NR	NR		
297	Difluoroethane, 1,2-		C2H4F2	624-72-6	11.86	NR	NR	NR		
298	Difluoromethane		CH2F2	75-10-5	12.71	NR	NR	NR		
299	Dihydrogen selenide		H2Se	7783-07-5	9.89	NA	1	NA	5	100
300	Diglycidyl ether	glycidic ether	C6H10O3	2238-07-5	~9.6	NA	3	NA		
301	Dihydroeugenol		C10H14O2	2785-87-7	~9	NA	0.4	NA		
302	Dihydrojasmane		C11H18O	1128-08-1	~9	NA	0.6	NA		
303	Dihydromyrcenol		C10H20O	18479-58-8	~9	NA	0.8	NA		
304	Dihydroxybenzene, 1,2-	catechol, benzene-1,2-diol	C6H6O2	120-80-9	8.56	NA	1	NA	5	100
305	Dihydroxybenzene, 1,3-	resorcinol	C6H6O2	108-46-3	8.63	NA	1	NA	5	100
306	Diiodomethane	methylene iodide	CH2I2	75-11-6	9.46	NA	1.2	NA		
307	Diisobutyl ketone	isovalerone	C9H18O	108-83-8	9.04	0.7	0.8	NA	4	80
308	Diisobutylene	2,4,4-trimethylpent-1-ene or 2,4,4-trimethylpent-2-ene	C8H16	107-39-1	8.91	0.9	0.7	0.5	3	60
309	Diisopropyl ether	isopropyl ether	C6H14O	108-20-3	9.20	0.95	0.92	0.62	3	70
310	Diisopropylamine		C6H15N	108-18-9	7.73	0.6	0.7	0.53	4	70
311	Diisopropylbenzene		C12H18	25321-09-9	~8.8	NA	0.5	NA		
312	Diketene		C4H4O2	674-82-8	9.6	NA	2.2	1.4	11	220
313	Dimethoxybenzene, 1,4-		C8H10O2	150-78-7	~9	NA	1.3	NA		
314	Dimethoxyethane, 1,2-	ethylene glycol dimethyl ether	C4H10O2	110-71-4	9.20	1.2	0.9	0.6		
315	Dimethoxymethane	formal	C3H8O2	109-87-5	10.00	13	2.8	1.2	7	140
316	Dimethyl carbonate		C3H6O3	616-38-6	10.52	NR	60	1.5	0	0
317	Dimethyl disulfide	DMDS	C2H6S2	624-92-0	8.46	NA	0.2	NA	1	23
318	Dimethyl ether	methyl ether	C2H6O	115-10-6	10.03	NA	1.3	NA	7	130
319	Dimethyl phosphite		C2H7O3P	868-85-9	10.53	NR	8	NA		
320	Dimethyl phthalate		C10H10O4	131-11-3	9.64	NA	1	NA	5	100
321	Dimethyl sulfate		C2H6O4S	77-78-1	~12	NR	NR	2.3	0	0
322	Dimethyl sulfoxide	DMSO	C2H6OS	67-68-5	9.10	32	20	9		
323	Dimethylacetamide N,N-	DMA	C4H9NO	127-19-5	8.81	NA	1.3	0.8	7	130
324	Dimethylacetylene		C4H6	503-17-3	9.58	NA	1	NA		

Index	Chemical name	Alternative name	Formula	CAS no.	IE, eV	Response Factor (RF)			Typical MDL, 10.6 eV lamp	Typical MDL, 10.6 eV lamp
						10.0 eV	10.6 eV	11.7 eV		
325	Dimethylamine		C2H7N	124-40-3	8.24	NA	1.5	2	7	140
326	Dimethylaminoethanol, 2-	dimethylethanolamine	C4H11NO	108-01-0	8.80	NA	1.5	NA	8	150
327	Dimethylaniline, NN-		C8H11N	121-69-7	7.12	0.5	0.6	NA	3	60
328	Dimethylboron bromide		C2H6BBr	5158-50-9	10.25	NA	4	NA		
329	Dimethylbutyl acetate	sec-hexyl acetate	C8H16O2	108-84-9	~9.5	NA	1.6	2	8	160
330	Dimethylcycloheptane, 1,2-		C9H18	13151-50-3	10.21	NA	1.3	NA		
331	Dimethylcyclohexane,1,2-	1,2-DMCH	C8H16	583-57-3	9.41	0.9	0.55	0.45	5	105
332	Dimethylcyclopentane		C7H14	1192-18-3	9.92	NA	1.2	NA		
333	Dimethylethylamine, NN-	DMEA	C4H11N	598-56-1	7.74	1.7	1.6	1.2	4	80
334	Dimethylformamide	DMF	C3H7NO	68-12-2	9.13	1.1	1.3	1.12	5	90
335	Dimethylhydrazine, 1,1-	UDMH	C2H8N2	57-14-7	8.05	NA	1	0.8	5	100
336	Dinitrobenzene, m-		C6H4N2O4	99-65-0	10.40	NA	3	NA	15	300
337	Dinitrobenzene, o-		C6H4N2O4	528-29-0	10.71	NA	NR	NA		
338	Dinitrobenzene, p-		C6H4N2O4	100-25-4	~10.58	NA	5	NA	25	500
339	Dinonyl phthalate		C26H42O4	84-76-4		NA	1	NA	5	100
340	Dimethylmethylphosphonate	DMMP	C3H9O3P	756-79-6	9.94	NA	5	NA		
341	Dimethyloctan-1-ol, 3,7-		C10H22O	106-21-8	~9	NA	1.2	NA		
342	Dimethyloctan-3-ol, 3,7-		C10H22O	78-69-3	~9	NA	1.2	NA		
343	Dimethylpentane, 2,4-		C7H16	108-08-7	~9.8	NA	1	NA		
344	Dimethylsilane		C2H8Si	1111-74-6	10.30	NR	2	NA		
345	Dimethylthiophosphoryl chloride		C2H6ClO2PS	2524-03-0	~9	NA	1	NA		
346	Di-n-butylamine		C8H19N	111-92-2	7.69	4	6	1		
347	Di-n-propylamine		C6H15N	142-84-7	7.8	1.5	1.5	0.7		
348	Dioxane, 1,4-	p-dioxane	C4H8O2	123-91-1	9.13	1.7	1.45	0.85	8	150
349	Dioxolane		C3H6O2	646-06-0	9.13	4.5	2.7	1.47		
350	Dipentene	limonene	C10H16	138-86-3	~8.6	0.8	0.9	1	5	90
351	Diphenyl ether	phenyl ether	C12H10O	101-84-8	8.09	1.7	1.5	1.4	4	80
352	Dipropylene Glycol Diacrylate		C12H18O5	57472-68-1		NA	NV	NA		
353	Dipropyl ether	propyl ether	C6H14O	111-43-3	9.30	NA	1	NA		
354	Dipropylene glycol		C6H14O3	110-98-5	~10	NA	4	NA		
355	Disilane		Si2H6	1590-87-0	9.74	NA	2	NA		
356	Disulfur decafluoride		S2F10	5714-22-7	12.77	NR	NR	NA		
357	Disulfur dibromide		S2Br2	13172-31-1	9.23	NA	1.5	NA		
358	Disulfur dichloride		S2Cl2	10025-67-9	9.40	NA	3	NA	15	300
359	Di-tert-butyl-p-cresol		C11H16O	2409-55-4		NA	1	NA	5	100
360	Di-tert-butyl-p-cresol		C15H24O	128-37-0	7.8	NA	0.3	NA		
361	Divinylbenzene		C10H10	1321-74-0	~8.2	0.4	0.4	NA	2	40
362	Divinylbenzene, 1,3-		C10H10	108-57-6	~8.3	0.25	0.3	NA		
363	Dodecane		C12H24	112-40-3	~8.8	NA	1	NA		
364	Dodecanol		C12H26O	112-53-8		NA	0.9	NA	5	90
365	Dodecanol, ethoxylated		(C2H4O)nC12H26O	9002-92-0		NA	NV	NA		
366	Enflurane		C4H2F5ClO	13838-16-9	11.70	NR	NR	NR		
367	Epichlorohydrin	1-chloro-2,3-epoxypropane	C3H5ClO	106-89-8	10.2	30	5	0.8	40	800
368	Epoxypropyl isopropyl ether, 2,3-	glycidyl isopropyl ether	C6H12O2	4016-14-2	~10	1.1	1.2	0.6	5	110
369	Estagole		C10H12O	140-67-0	~9	NA	0.7	NA		
370	Ethane		C2H6	74-84-0	11.56	NR	NR	3		
371	Ethanol	alcohol, ethyl alcohol	C2H6O	64-17-5	10.43	NR	11	3	45	870

Index	Chemical name	Alternative name	Formula	CAS no.	IE, eV	Response Factor (RF)			Typical MDL, 10.6 eV lamp	Typical MDL, 10.6 eV lamp
						10.0 eV	10.6 eV	11.7 eV		
372	Ethanolamine		C2H7NO	141-43-5	10.47	NR	3	3	15	300
373	Ethoxy-2-methylpropane, 1-		C6H14O	627-02-1	9.3	NA	1	NA		
374	Ethoxy-2-propanol, 1-	propylene glycol ethyl ether	C5H12O2	1569-02-4	~9.6	NA	2.4	0.8	10	200
375	Ethoxy-butane, 2-		C6H14O	19316-73-5	9.32	NA	1	NA		
376	Ethoxyethanol, 2-	Ethyl Cellosolve®, EGME	C4H10O2	110-80-5	9.60	5	2	1.7	150	3000
377	Ethoxyethyl acetate, 2-		C6H12O3	111-15-9	~10	NA	3	NA	15	300
378	Ethyl 2,2,2-trifluoroethyl ether	TFEE	C4H7F3O	461-24-5	10.27	NA	5	NA		
379	Ethyl 2-methylbutyrate		C7H14O2	7452-79-1	~9	1.8	1.4	0.72		
380	Ethyl acetate		C4H8O2	141-78-6	10.01	40	4.5	1.4	20	360
381	Ethyl acetoacetate		C6H10O3	141-97-9	~9.5	NA	3	NA		
382	Ethyl acrylate		C5H8O2	140-88-5	10.3	15	2.3	1	10	200
383	Ethyl benzoate		C9H10O2	93-89-0	8.9	NA	0.9	NA		
384	Ethyl butyrate		C6H12O2	105-54-4	~9.9	3.3	1.4	1	5	100
385	Ethyl chloroformate		C3H5O2Cl	541-41-3	10.64	NR	80	2	400	8300
386	Ethyl cyanoacrylate		C6H7O2N	7085-85-0	~10	NA	1.5	NA	8	150
387	Ethyl decanoate		C12H24O2	110-38-3	~9.6	NA	1.8	NA	10	180
388	Ethyl formate		C3H6O2	109-94-4	10.61	NR	35	1.76	150	3000
389	Ethyl hexanoate	(Ethyl caproate; FEMA 2439)	C8H16O2	123-66-0	~9.75	3.3	1.6	0.7	15	260
390	Ethyl hexanol, 2-		C8H18O	104-76-7	~9.8	NA	1.5	1		
391	Ethyl hexyl acrylate, 2-		C11H20O2	103-11-7	~9	NA	1	0.5	5	100
392	Ethyl iodide	iodoethane	C2H5I	75-03-6	9.34	0.3	0.3	0.3		
393	Ethyl isopropyl ketone	2-methylpentan-3-one	C6H12O	565-69-5	9.10	NA	0.8	NA		
394	Ethyl lactate		C5H10O3	97-64-3	~10	5	2.1	1.09	15	300
395	Ethyl mercaptan	thioethanol	C2H6S	75-08-1	9.29	0.55	0.6	0.55	3	70
396	Ethyl methacrylate		C6H10O2	97-63-2	~9.5	1.6	1.06	0.86		
397	Ethyl methyl carbonate		C4H8O3	623-53-0	10.40	NR	18	1.2		
398	Ethyl morpholine, 4-		C6H13NO	100-74-3	~8	NA	0.6	NA		
399	Ethyl octanoate		C10H20O2	106-32-1	~9.7	NA	2.3	NA	12	230
400	Ethyl perfluorobutyl ether		C6H5F9O	163702-05-4	~11	NR	NR	20		
401	Ethyl phenyl acetate		C10H12O2	101-97-3	~9	NA	1.2	NA		
402	Ethyl propanoate		C5H10O2	105-37-3	10.01	6	2.5	1.2		
403	Ethyl tert-butyl ether		C6H14O	637-92-3	9.39	NA	0.8	NA		
404	Ethyl-2-methyl benzene, 1-	2-ethyltoluene	C9H12	611-14-3	~8.7	0.45	0.5	NA		
405	Ethyl-3-ethoxypropionate		C7H14O3	763-69-9	~9.5	NA	3	NA		
406	Ethylacetylene		C4H6	107-00-6	10.18	NA	3	NA		
407	Ethylamine		C2H7N	75-04-7	8.86	NA	1	1	5	100
408	Ethylbenzene		C8H10	100-41-4	8.76	0.6	0.56	0.54	3	50
409	Ethylcyclohexane		C8H16	1678-91-7	9.54	1.3	0.8	0.48		
410	Ethylene	ethene	C2H4	74-85-1	10.51	NR	8	3	40	800
411	Ethylene carbonate		C3H4O3	96-49-1	10.40	NR	40	NA		
412	Ethylene cyanohydrin		C3H5NO	109-78-4	~10.8	NR	NR	1		
413	Ethylene dinitrate		C2H4O6N2	628-96-6	~10.8	NR	NR	NA		
414	Ethylene glycol		C2H6O2	107-21-1	10.16	9	9	4.1	100	2000
415	Ethylene glycol diacetate		C6H10O4	111-55-7	~10	NA	4	NA		
416	Ethylene glycol monopropylether	2-propoxyethanol	C5H12O2	2807-30-9	~9	NA	3	NA		
417	Ethylene oxide	oxirane	C2H4O	75-21-8	10.56	NR	15	2	75	1500
418	Ethylenediamine		C2H8N2	107-15-3	8.60	10	10	8		
419	Ethyleneimine		C2H5N	151-56-4	9.20	NA	2	NA		

Index	Chemical name	Alternative name	Formula	CAS no.	IE, eV	Response Factor (RF)			Typical MDL, 10.6 eV lamp	Typical MDL, 10.6 eV lamp
						10.0 eV	10.6 eV	11.7 eV		
420	Ethylhexanal, 2-		C8H16O	123-05-7	~9	NA	1.5	NA		
421	Ethylhexanoic acid, 2-		C8H16O2	149-57-5	~10	16	5	2.9		
422	Ethylhexenal, 2-		C8H14O	645-62-5	~9	NA	1.3	NA		
423	Eucalyptol		C10H18O	470-82-6	~9	NA	0.6	NA		
424	Eugenol		C10H12O2	97-53-0	~9	NA	0.4	NA		
425	Eugenol methyl ether		C11H14O2	93-15-2	~9	NA	0.4	NA		
426	Fenchol		C10H18O	1632-73-1	~9	NA	0.4	NA		
427	Ferrocene		C10H10Fe	102-54-5	6.88	NA	0.8	NA	4	80
428	Fluorine		F2	7782-41-4	15.70	NR	NR	NA		
429	Fluoro-2-propanone, 1-		C3H5FO	430-51-3	9.92	NA	NR	1		
430	Fluorobenzene		C6H5F	462-06-6	9.2	0.83	0.74	0.78		
431	Fluorobenzoic acid, 4-		C7H5FO2	456-22-4	9.91	NA	2	NA		
432	Fluoroethane		C2H5F	353-33-6	11.78	NR	NR	NA		
433	Fluoromethane		CH3F	593-53-3	12.47	NR	NR	NA		
434	Formaldehyde		CH2O	50-00-0	10.87	NR	NR	0.6		
435	Formamide		CH3ON	75-12-7	10.20	NA	2	NA	10	200
436	Formic acid		CH2O2	64-18-6	11.05	NR	NR	5		
437	Furan		C4H4O	110-00-9	8.88	NA	0.4	NA		
438	Furfural		C5H4O2	98-01-1	9.21	NA	0.8	0.5	7	140
439	Furfuryl alcohol		C5H6O2	98-00-0	~9.9	NA	2	NA	10	200
440	Furfuryl mercaptan		C5H6OS	98-02-2	~9	NA	0.5	NA		
441	Gasoline			8006-61-9	~9.9	1	0.9	NA	5	105
442	Geranial		C10H16O	141-27-5	~9	NA	0.6	NA		
443	Geraniol		C10H18O	106-24-1	~9	NA	0.7	NA		
444	Geranyl acetate		C12H20O2	105-87-3	~9	NA	1.2	NA		
445	Germane		GeH4	7782-65-2	11.34	NR	10	NA	50	1000
446	Glutaraldehyde	1,5-pentanedial	C5H8O2	111-30-8	~9.6	NA	0.9	0.6	5	90
447	Glycerol Propoxy Triacrylate		C12H14O6	52408-84-1		NA	NV	NA		
448	Glycidol	2,3-epoxypropanol	C3H6O2	556-52-5	~10.8	NR	NR	2		
449	Glycidyl methacrylate		C7H10O3	106-91-2	~10	NR	1.2	NA		
450	Glycolaldehyde		C2H4O2	141-46-8	~10.4	NR	5	NA		
451	Glyoxal		C2H2O2	107-22-2	10.2	NA	1	NA		
452	Guaiacol	2-methoxyphenol	C7H8O2	90-05-1	~9	NA	0.8	NA		
453	Halothane	Fluothane-2-bromo-2-chloro-1,1,1-trifluoroethane	CF3CHBrCl	151-67-7	11.00	NR	NR	0.6		
454	Helium		He	7440-59-7	24.59	NR	NR	NA		
455	Heptan-2-one		C7H14O	110-43-0	9.33	0.97	0.85	0.54	4	70
456	Heptan-3-one		C7H14O	106-35-4	9.02	0.81	0.73	0.59	4	75
457	Heptane, n-		C7H16	142-82-5	9.92	11	2.2	0.5	10	200
458	Heptanol		C7H16O	53535-33-4	~9.8	NA	1.7	NA		
459	Heptene, 1-		C7H14	592-76-7	9.34	1.1	0.88	0.51		
460	Heptylcyclopentan-1-one, 2-		C12H22O	137-03-1	~9	NA	0.8	NA		
461	Heptyne, 1-		C7H12	628-71-7	10.04	NA	2	NA		
462	Hex-1-en-3-ol		C6H12O	4798-44-1	~9	NA	0.9	NA		
463	Hexachlorodisilane		Cl6Si2	13465-77-5	10.40	NR	8	NA		
464	Hexachloroethane	R-110	C2Cl6	67-72-1	11.22	NR	NR	1		
465	Hexafluoroethane	R-116	C2F6	76-16-4	13.60	NR	NR	NR		
466	Hexafluoropropylene		C3F6	116-15-4	10.60	NR	NR	4		

Index	Chemical name	Alternative name	Formula	CAS no.	IE, eV	Response Factor (RF)			Typical MDL, 10.6 eV lamp	Typical MDL, 10.6 eV lamp
						10.0 eV	10.6 eV	11.7 eV		
467	Hexamethyldisilazane, 1,1,1,3,3,3-	HMDS	C6H18NSi2	999-97-3	8.60	NA	1	0.19	5	100
468	Hexamethyldisiloxane	hexamethylsilazane	C6H18OSi2	107-46-0	9.60	NA	0.3	NA	1	30
469	Hexamethylene diisocyanate		C8H12N2O2	822-06-0	~9	NA	1.5	NA		
470	Hexamethyleneimine		C6H13N	111-49-9	8.41	NA	1.1	NA		
471	Hexan-2-one		C6H12O	591-78-6	9.34	0.7	0.8	NA	4	80
472	Hexane, n-		C6H14	110-54-3	10.13	13	3	0.6	20	420
473	Hexanoic acid		C6H12O2	142-62-1	10.12	NA	4	NA		
474	Hexanol		C6H14O	111-27-3	9.89	7	2	0.66		
475	Hexene, 1-		C6H12	592-41-6	9.44	1.1	0.98	0.61	5	90
476	Hexenyl acetate, cis-3-		C8H14O2	3681-71-8	~9	1.2	1	0.55		
477	Hexenyl butyrate, cis-3-		C10H18O2	16491-36-4	~9	NA	1.5	NA		
478	Hexylaldehyde	hexanal	C6H12O	66-25-1	9.72	1.8	1.2	0.54		
479	Hydrazine		H4N2	302-01-2	8.93	NA	3	2.1	15	300
480	Hydrazoic acid		HN3	7782-79-8	10.72	NR	NR	NA		
481	Hydrogen		H2	1333-74-0	15.43	NR	NR	NR		
482	Hydrogen bromide		HBr	10035-10-6	11.62	NR	NR	NA		
483	Hydrogen chloride		HCl	7647-01-0	12.74	NR	NR	NA		
484	Hydrogen cyanide		HCN	74-90-8	13.60	NR	NR	NR		
485	Hydrogen fluoride		HF	7664-39-3	15.98	NR	NR	NA		
486	Hydrogen iodide		HI	10034-85-2	10.39	NR	5	NA		
487	Hydrogen peroxide		H2O2	7722-84-1	10.58	NR	4	NA	20	400
488	Hydrogen selenide		H2Se	7783-07-5	9.88	NA	2	NA		
489	Hydrogen sulfide		H2S	7783-06-4	10.46	NR	4	1.5		
490	Hydroquinone		C6H6O2	123-31-9	7.94	NA	0.8	NA	4	80
491	Hydrogen telluride		H2Te	7783-09-7	9.14	NA	2	NA		
492	Hydroxybutanal, 3-		C4H6O2	107-89-1	~9	NA	2	NA		
493	Hydroxycitronellal		C10H20O2	107-75-5	~9	NA	1	NA		
494	Hydroxyethyl acrylate		C5H8O3	818-61-1	~10	NA	1.2	NA		
495	Hydroxylamine		H3NO	7803-49-8	10.00	NA	2	NA		
496	Hydroxypropyl acrylate, 2-	1,2-propanediol, 1-acrylate; 2-hydroxypropyl	C6H10O3	999-61-1	~9	NA	1.5	NA	8	150
497	Iminodiethanol 2,2'-	Diethanolamine	C4H11NO2	111-422		NA	1.6	NA	8	160
498	Indene		C9H8	95-13-6	8.81	NA	0.5	NA	2	50
499	Indole		C8H7N	120-72-9	7.76	NA	0.4	NA		
500	Iodine		I2	7553-56-2	9.31	0.1	0.2	NA	1	15
501	Iodobenzene		C6H5I	591-50-4	8.73	NA	0.2	NA		
502	Iodoethene	vinyl iodide	C2H3I	593-66-8	9.3	NA	1.2	NA		
503	Iodoform	triiodomethane	CHI3	75-47-8	9.25	NA	1.5	NA	8	150
504	Iodomethane	methyl iodide	CH3I	74-88-4	9.54	NA	0.4	0.26	2	40
505	Isoalkanes, C10-C13		C8H18O	68551-17-7	~9.6	NA	1	NA		
506	Isoamyl acetate		C7H14O2	123-92-2	~9.7	6	1.5	0.66	8	160
507	Isoamyl salicylate		C12H16O3	87-20-7	~9	NA	1	NA		
508	Isoamylene		C5H10	513-35-9	8.69	0.86	0.82	0.63		
509	Isobornyl acetate		C12H20O2	125-12-2	~9	NA	0.5	NA		
510	Isobutane		C4H10	75-28-5	10.57	NR	8	1.2	40	800
511	Isobutanol		C4H10O	78-83-1	10.12	13	3	1.1	20	350
512	Isobutyl acetate		C6H12O2	110-19-0	9.90	10	2	0.8	10	230
513	Isobutyl acrylate		C7H12O2	106-63-8	~9.5	5	1.2	0.8	7	130

Index	Chemical name	Alternative name	Formula	CAS no.	IE, eV	Response Factor (RF)			Typical MDL, 10.6 eV lamp	Typical MDL, 10.6 eV lamp
						10.0 eV	10.6 eV	11.7 eV		
514	Isobutylbenzene		C10H14	538-93-2	8.68	0.4	0.4	NA		
515	Isobutylene		C4H8	115-11-7	9.24	1	1	1	5	100
516	Isobutylene epoxide		C4H8O	558-30-5	10.00	NA	3	NA		
517	Isobutyraldehyde		C4H8O	78-84-2	9.74	NA	1.2	NA	6	120
518	Isobutyric acid		C4H8O2	79-31-2	10.24	15	4.4	1.8		
519	Isocyanic acid		HNCO	75-13-8	11.60	NR	NR	NA		
520	Isodecanol		C10H22O	25339-17-7	~9.8	NA	0.9	1	5	90
521	Isoeugenol		C10H12O2	97-54-1	~9	NA	0.4	NA		
522	Isoflurane		C3H2ClF5O	26675-46-7	~11	NR	NR	50		
523	Isoheptane		C7H16	591-76-4	9.84	NA	1.2	NA		
524	Isojasmone		C11H18O	95-41-0	~9	NA	0.7	NA		
525	Isomenthone		C10H18O	1196-31-2	9.86	NA	0.6	NA		
526	Isononanal		C9H18O	5435-64-3	~9.6	1.4	0.9	0.5		
527	Isononanol		C9H20O	3452-97-9	~9.8	NA	1.5	1	8	150
528	Isooctane	2,2,4-trimethylpentane	C8H18	540-84-1	9.86	3.2	1.1	0.51	5	100
529	Isooctanol		C8H18O	26952-21-6	~9.8	NA	1.7	1	9	170
530	Isopentane		C5H12	78-78-4	10.32	NR	4	4	30	600
531	Isopentanol		C5H12O	137-32-6	9.86	6	2	0.8		
532	Isopentene		C5H10	563-46-2	9.12	NA	0.8	NA		
533	Isophorone		C9H14O	78-59-1	9.07	1	0.8	1.1	4	75
534	Isophorone diisocyanate		C12H18N2O2	4098-71-9	~9	NA	0.6	NA		
535	Isoprene	2-methyl-1,3-butadiene	C5H8	78-79-5	8.85	NA	0.8	NA	3	70
536	Isopropanol	IPA, 2-propanol	C3H8O	67-63-0	10.17	25	4	2	22	440
537	Isopropanolamine		C3H9NO	78-96-6	~9.6	NA	1.5	NA		
538	Isopropoxyethanol, 2-	ethylene glycol isopropyl ether	C5H12O2	109-59-1	~10.3	1.5	1.2	0.8		
539	Isopropyl acetate		C5H10O2	108-21-4	9.99	8	2.4	1.1	10	220
540	Isopropyl chloroformate		C4H7O2Cl	108-23-6	~10.2	NA	1.6	NA	8	160
541	Isopropylidenediphenol, 4, 4-	Bisphenol A	C15H16O2	80-05-7		NA	NA	NA		
542	Isopropyl mercaptan		C3H8S	75-33-2	9.15	NA	0.6	NA		
543	Isopropyl nitrite		C3H7NO2	541-42-4	10.23	NA	4	NA		
544	Isopropylamine		C3H9N	75-31-0	8.72	1	1	1		
545	Isopropylaminoethanol, 2-		C5H13NO	109-56-8	~9	NA	2	NA		
546	Isopropylcyclohexane		C9H18	696-29-7	9.33	1.1	0.7	0.53		
547	Isopropylglycol acetate		C7H14O2	19234-20-9	~9.5	NA	1.2	NA		
548	Isothiazole		C3H3NS	288-16-4	9.55	NA	3	NA		
549	Isovaleraldehyde		C5H10O	590-86-3	9.72	1.5	1.3	0.8		
550	Isovaleric Acid		C5H10O2	503-74-2	~10.2	25	5.5	1.6		
551	Isoxazole		C3H3NO	288-14-2	9.96	NA	NA	NA		
552	Jasmal		C11H22O3	1322-17-4	~9	NA	1.4	NA		
553	Jasmone, cis-		C11H16O	488-10-8	~9	NA	0.5	NA		
554	Jet Fuel Jp-4	Jet B, wide cut aviation fuel			~9	0.7	0.8	0.42		
555	Jet Fuel Jp-5	kerosene aviation fuel			~9	0.6	0.7	0.46		
556	Jet Fuel Jp-8	kerosene aviation fuel			~9	0.6	0.7	0.32		
557	Kerosene	C10-C16		8008-20-6	~8	0.7	0.8	NA	4	90
558	Ketene		C2H2O	463-51-4	9.62	NA	3	NA	15	300
559	Krypton		Kr	7439-90-9	14.00	NR	NR	NR		
560	Linalool oxide		C10H18O2	14049-11-7	~9	NA	0.6	NA		
561	Linalyl acetate		C12H20O2	115-95-7	~9	NA	1.1	NA		

Index	Chemical name	Alternative name	Formula	CAS no.	IE, eV	Response Factor (RF)			Typical MDL, 10.6 eV lamp	Typical MDL, 10.6 eV lamp
						10.0 eV	10.6 eV	11.7 eV		
562	Liquefied petroleum gas	LPG, predominantly propane and butanes		68476-85-7	10.95	NR	NR	NA		
563	Maleic anhydride	furan-2,5-dione	C4H2O3	108-31-6	9.9	NA	2	NA	10	200
564	Mandelic acid		C8H8O3	90-64-2		NA	0.8	NA		
565	Menthol		C10H20O	1490-04-6	~9	NA	0.5	NA		
566	Menthone		C10H18O	89-80-5	~9	NA	0.4	NA		
567	Mercaptoacetic acid		C2H4O2S	68-11-1	~9.8	NA	1	NA	5	100
568	Mercury		Hg	7439-97-6	10.44	NA	NA	NA		
569	Metalddehyde		C8H16O4	108-62-3	~9.7	NA	2	NA		
570	Methacrylamide		C4H7NO	79-39-0	~10	NR	2	NA		
571	Methacrylic acid		C4H6O2	79-41-4	10.15	NA	2.3	NA	12	230
572	Methacrylonitrile		C4H5N	126-98-7	10.34	NR	5	NA	25	500
573	Methane	natural gas	CH4	74-82-8	12.51	NR	NR	NR		
574	Methanol		CH4O	67-56-1	10.85	NR	NR	2.9	1000	20000
575	Methoxy-1-butanol, 3-		C5H12O2	2517-43-3	~9.56	NA	3	NA		
576	Methoxy-1-propanol, 2-		C4H10O2	1589-47-5	9.30	NA	2	NA		
577	Methoxy-2,2-dimethylpropane	methyl neopentyl ether	C6H14O	1118-00-9	9.3	NA	0.9	NA		
578	Methoxybutyl acetate, 3-		C7H14O3	4435-53-4	~9	NA	2	NA		
579	Methoxyethane	methyl ethyl ether	C3H8O	540-67-0	9.72	NA	1	NA		
580	Methoxyethanol, 2-	methyl cellosolve, EGME, ethylene glycol monomethyl ether	C3H8O2	109-86-4	9.6	NA	2.7	1.4	15	270
581	Methoxyethene	methyl vinyl ether	C3H6O	107-25-5	8.95	NA	1	NA		
582	Methoxyethoxyethanol, 2-	diethylene glycol monomethyl ether	C5H12O3	111-77-3	10.00	NA	1.4	0.9	7	140
583	Methoxyethyl acetate		C5H10O3	110-49-6	~9.6	NA	2.7	1.4		
584	Methoxyethyl ether, 2-	diglyme, diethylene glycol dimethyl ether	C6H14O3	111-96-6	9.80	NA	1	NA		
585	Methoxymethlethoxy-2- propanol	DPGME	C7H16O3	34590-94-8	~10	NA	1.3	NA	7	130
586	Methoxypropan-2-ol, 1-	1M2P, PGME, propylene glycol methyl ether	C4H10O2	107-98-2	~9.6	2.7	1.6	0.95	15	300
587	Methoxypropane, 2-		C4H10O	598-53-8	9.45	NA	1.2	NA		
588	Methoxypropyl acetate	PGMEA, propylene glycol methyl ether acetate	C6H12O3	108-65-6	~9	2.1	1.6	0.74	6	120
589	Methyl 2-methylpropanoate		C5H10O2	547-63-7	9.86	NA	2	NA		
590	Methyl acetate		C3H6O2	79-20-9	10.27	NR	7	1.8	25	500
591	Methyl acetoacetate		C5H8O3	105-45-3	9.81	NA	3	NA		
592	Methyl acrylate		C4H6O2	96-33-3	10.25	80	3.6	1.1	17	340
593	Methyl anthranilate		C8H9NO2	134-20-3	~9	NA	0.4	NA		
594	Methyl benzoate		C8H8O2	93-58-3	9.32	NA	1.2	NA		
595	Methyl bromide	bromomethane	CH3Br	74-83-9	10.54	NR	1.9	1.3	10	190
596	Methyl cyanoacrylate		C5H5O2N	137-05-3	10.98	NR	NR	2	25	500
597	Methyl dimethylacrylate		C6H10O2	924-50-5	~9.6	NA	2.5	NA		
598	Methyl ethyl ketone	MEK, Butan-2-one	C4H8O	78-93-3	9.51	2	0.96	1.2	4	80
599	Methyl ethyl ketone peroxides	MEKP	C8H18O6	1338-23-4	~9	NA	0.8	NA	4	80
600	Methyl formate		C2H4O2	107-31-3	10.82	NR	NR	NA		
601	Methyl heptyne carbonate		C9H14O2	111-12-6	~9	NA	1.3	NA		
602	Methyl ionone		C14H22O	1335-46-2	~9	NA	0.4	NA		
603	Methyl isobutyl ketone	MIBK, 4-methylpentan-2-one	C6H12O	108-10-1	9.30	1.01	0.9	0.7	4	80
604	Methyl isocyanate		C2H3NO	624-83-9	10.67	NR	5	1.5		
605	Methyl isopropyl ketone	MIPK, 2-methylbutan-3-one	C5H10O	563-80-4	9.31	0.96	0.99	0.92		
606	Methyl isothiocyanate		C2H3NS	556-61-6	9.25	NA	0.6	0.4	3	60

Index	Chemical name	Alternative name	Formula	CAS no.	IE, eV	Response Factor (RF)			Typical MDL, 10.6 eV lamp	Typical MDL, 10.6 eV lamp
						10.0 eV	10.6 eV	11.7 eV		
607	Methyl mercaptan		CH4S	74-93-1	9.44	0.6	0.7	1	4	70
608	Methyl methacrylate		C5H8O2	80-62-6	9.7	2.1	1.31	0.92	8	160
609	Methyl perfluorobutyl ether		C5H3F9O	163702-07-6	~11	NR	NR	30		
610	Methyl phenyl acetate		C9H10O2	101-41-7	~9	NA	0.4	NA		
611	Methyl propargyl ether		C4H6O	627-41-8	9.78	NA	2	NA		
612	Methyl propionate		C4H8O2	554-12-1	10.15	36	3.8	1.46		
613	Methyl propynoate		C4H4O2	922-67-8	10.30	NR	10	0.9		
614	Methyl salicylate		C8H8O3	119-36-8	7.65	NA	0.8	NA	6	120
615	Methyl sulfide	DMS	C2H6S	75-18-3	8.69	0.7	0.8	0.6	3	50
616	Methyl tert-butyl ether	MTBE	C5H12O	1634-04-4	9.24	1.02	1	0.8	4	80
617	Methyl thiocyanate		C2H3NS	556-64-9	9.96	NA	2	NA		
618	Methyl thioglyconate		C3H6O2S	2365-48-2	~10	NA	1	NA		
619	Methyl undecanal, 2-		C12H24O	110-41-8	~9	NA	1.1	NA		
620	Methyl vinyl ketone		C4H6O	78-94-4	9.65	NA	0.6	NA		
621	Methyl-1-butene, 3-		C5H10	563-45-1	9.51	NA	0.8	NA		
622	Methyl-2-butanol, 3-		C5H12O	598-75-4	9.88	NA	3.3	NA		
623	Methyl-2-hexenoic acid, trans-3-		C7H12O2	027960-21-0	~10	NA	1.5	NA		
624	Methyl-2-propen-1-ol, 2-		C4H8O	513-42-8	9.24	1.6	1.3	1.2	5	100
625	Methyl-2-pyrrolidinone, N-	NMP, N-methylpyrrolidone	C5H9NO	872-50-4	9.17	NA	0.9	0.9	5	90
626	Methyl-4,6-dinitrophenol, 2-		C7H6N2O5	534-52-1		NA	3	NA	15	300
627	Methyl-5-hepten-2-one, 6-		C8H14O	110-93-0	~9.4	0.76	0.63	0.89	4	80
628	Methylamine		CH5N	74-89-5	8.97	NA	1.5	1	7	140
629	Methylbutan-1-ol, 3-		C5H12O	123-51-3	9.8	10	2.3	0.8	17	340
630	Methylbutanal, 2-		C5H10O	96-17-3	9.59	1.3	1.2	0.8		
631	Methylbutyric acid, 2-		C5H10O2	116-53-0	~10.2	20	6	1.6		
632	Methylchloroformate		C2H3O2Cl	79-22-1	11.36	NR	NR	1		
633	Methylcyclohexane		C7H14	108-87-2	9.85	1	1.1	0.53	6	110
634	Methylcyclohexanol		C7H14O	25639-42-3	9.80	NA	2.4	NA		
635	Methylcyclohexanol, 4-		C7H14O	589-91-3	9.8	NA	2.4	NA	12	240
636	Methylcyclohexanone, 2-		C7H12O	583-60-8	9.05	NA	1	NA	5	100
637	Methylcyclopentane		C6H12	96-37-7	9.85	NA	1.5	NA		
638	Methylenepentane, 3-		C6H12	760-21-4	9.06	NA	0.9	NA		
639	Methylheptan-3-one, 5-	Amyl ethyl ketone	C8H16O	541-85-5	~9.1	0.88	0.77	0.56	4	75
640	Methylhexan-2-one, 5-	MIAC, methyl isoamyl ketone	C7H14O	110-12-3	9.28	0.91	0.7	0.58	4	75
641	Methylhydrazine		CH6N2	60-34-4	8.00	NA	1.3	1.3	7	130
642	Methyl-N-2,4,6-tetranitroaniline, N-		C7H5N5O8	479-45-8		NA	3	NA	15	300
643	Methylpent-3-en-2-one, 4-		C6H10O	141-79-7	9.10	0.66	0.6	1.1	4	70
644	Methylpentan-2-ol, 4-	MIBC, methyl isobutylcarbinol	C6H14O	108-11-2	~9.8	3	1.4	0.68	14	280
645	Methylpentane, 2-		C6H14	107-83-5	10.12	34	3	0.58		
646	Methylpentane, 3-		C6H14	96-14-0	10.08	24	2.5	0.64		
647	Methylpentane-2,4-diol, 2-	hexylene glycol	C6H14O2	107-41-5	~9.6	NA	4	NA	20	400
648	Methylpropanoyl chloride, 2-		C4H7ClO	79-30-1	~9	NA	6	NA		
649	Methylpyrrole, N-		C5H7N	96-54-8	7.95	0.8	0.9	0.56		
650	Methylstyrene		C9H10	25013-15-4	8.30	0.5	0.5	1	3	50
651	Methylthiopropional, 3-		C4H8OS	3268-49-3	~9.5	NA	2	NA		
652	Mineral oil			8042-47-5	~9	0.7	0.8	NA	4	80
653	Mineral spirits	Stoddard solvent, Varsol, Viscor		64475-85-0	~9	0.7	0.8	0.39	4	80

Index	Chemical name	Alternative name	Formula	CAS no.	IE, eV	Response Factor (RF)			Typical MDL, 10.6 eV lamp	Typical MDL, 10.6 eV lamp
						10.0 eV	10.6 eV	11.7 eV		
654	Monoisobutanolamine		C4H11NO	124-68-5	~9	NA	1.6	NA		
655	Morpholine		C4H9NO	110-91-8	8.88	2	4	1		
656	Myrcene	7-methyl-3-methylene-1,6-octadiene	C10H16	123-35-3	~8.2	NA	0.5	NA		
657	Naphtha, hydrotreated heavy		CnH(2n+2)	64742-48-9	~10	NA	1	NA		
658	Naphthalene		C10H8	91-20-3	8.14	0.4	0.4	0.4	2	45
659	Naphthol methyl ether, 2-		C11H10O	93-04-9	~9	NA	0.5	NA		
660	Neon		Ne	09-01-7440	21.56	NR	NR	NR		
661	Neopentane		C5H12	207-343-7	10.21	NA	3	NA		
662	Neopentyl alcohol		C5H12O	75-84-3	9.72	NA	2	NA		
663	Nitric oxide		NO	10102-43-9	9.27	NA	8	2.8	40	800
664	Nitroaniline 4-		C6H6N2O2	100-01-6	8.56	NA	0.8	NA	4	80
665	Nitrobenzene		C6H5NO2	98-95-3	9.92	NA	1.7	1.6	10	170
666	Nitroethane		C2H5NO2	79-24-3	10.88	NR	NR	2.4		
667	Nitrogen trichloride		NCI3	10025-85-1	10.1	NA	1	NA	5	100
668	Nitrogen		N2	7727-37-9	15.58	NR	NR	NR		
669	Nitrogen dioxide		NO2	10102-44-0	9.58	NA	10	NA	50	1000
670	Nitrogen trifluoride		NF3	7783-54-2	12.97	NR	NR	NA		
671	Nitromethane		CH3NO2	75-52-5	11.08	NR	NR	2.71		
672	Nitropropane, 1-		C3H7NO2	108-03-2	10.81	NR	NR	NA		
673	Nitropropane, 2-		C3H7NO2	79-46-9	10.71	NR	NR	2		
674	Nitrous oxide		N2O	10024-97-2	12.89	NR	NR	NA		
675	N-Methylolacrylamide		C4H7NO2	924-42-5	~10.3	NR	2	NA		
676	Nonane		C9H20	111-84-2	9.72	4.7	1.4	0.4	6	130
677	Nonanol (mixed isomers)		C9H20O	143-08-8	~9.8	NA	1.2	NA		
678	Nonene (mixed isomers)		C9H18	27215-95-8	~9.3	NA	0.6	NA		
679	Nonene, 1-		C9H18	124-11-8	~9.4	NA	0.6	NA		
680	Norbornadiene, 2,5-		C7H8	121-46-0	8.38	0.7	0.6	0.52	3	60
681	Ocimene		C10H16	502-99-8	8.60	NA	0.6	NA		
682	Octachloronaphthalene		C10Cl8	2234-13-1		NA	1	NA	5	100
683	Octamethylcyclotetrasiloxane		C6H12O4Si4	556-67-2	~10	NA	0.3	NA		
684	Octamethyltrisiloxane		C8H24O2Si3	107-51-7	10.04	NA	0.3	NA		
685	Octane		C8H18	111-65-9	9.8	7	1.6	0.44	8	160
686	Octanol (mixed isomers)	capryl alcohol, octyl alcohol	C8H18O	111-87-5	~9.8	NA	1.5	NA		
687	Octene (mixed isomers)		C8H16	25377-83-7	~9.4	NA	0.7	NA		
688	Octene, 1-		C8H16	111-66-0	9.43	1.1	0.7	0.43	3	70
689	Oxalic acid		C2H2O4	144-62-7	11.20	NA	NR	NA		
690	Oxalonnitrile		C2N2	460-19-5	13.57	NR	NR	NA		
691	Oxalyl bromide		C2Br2O2	15219-34-8	10.49	NR	5	NA		
692	Oxydiethanol, 2,2-	diethylene glycol	C4H10O3	111-46-6	~10.3	NR	2	NA	20	400
693	Oxygen		O2	7782-44-7	12.07	NR	NR	NR		
694	Ozone		O3	10028-15-6	12.52	NR	NR	NR		
695	Paraffin wax, fume			8002-74-2	~10	NA	1	NA	5	100
696	Paraffins, normal			64771-72-8	~9.5	NA	1	1	5	100
697	Paraldehyde		C6H12O3	123-63-7	~9.7	4.8	2.2	0.75		
698	Pentacarbonyl iron		FeC5O5	13463-40-6	~8	NA	1	NA	5	100
699	Pentachloroethane		C2Cl5	76-01-7	11.28	NR	NR	NA		
700	Pentachlorofluoroethane		C2Cl5F	354-56-3	~11.8	NR	NR	NA		
701	Pentafluoroethane		C2HF5	354-33-6	~12.5	NR	NR	NA		

Index	Chemical name	Alternative name	Formula	CAS no.	IE, eV	Response Factor (RF)			Typical MDL, 10.6 eV lamp	Typical MDL, 10.6 eV lamp
						10.0 eV	10.6 eV	11.7 eV		
702	Pentafluoropropane-1,1,1,3,3,		C3H3F5	460-73-1		NA	NR	NA		
703	Pentan-2-one	MPK, methyl propyl ketone	C5H10O	107-87-9	9.38	1.03	0.99	0.9	4	80
704	Pentan-3-one	diethyl ketone	C5H10O	96-22-0	9.31	0.75	0.77	1	4	80
705	Pentanal	pentyl aldehyde	C5H10O	110-62-3	9.74	1.75	1.5	0.7		
706	Pentandione, 2,4-	acetyl acetone	C5H8O2	123-54-6	8.85	0.85	1.2	0.72	4	75
707	Pentane		C5H12	109-66-0	10.35	NR	7	0.7	40	800
708	Pentanoic acid		C5H10O2	109-52-4	10.53	52	8	1.6		
709	Pentanol, 2-		C5H12O	6032-29-7	9.78	16	2	1		
710	Pentanol, 3-		C5H12O	584-02-1	9.76	3.5	1.7	0.9		
711	Pentene, 1-		C5H10	109-67-1	9.49	1	0.92	0.63		
712	Pentylcyclopentan-1-one, 2-		C10H18O	4819-67-4	~9	NA	1	NA		
713	Pentylcyclopentane		C10H20	3741-00-2	9.91	NA	1.1	NA		
714	Pentyne, 1-		C5H8	627-19-0	10.10	NA	3	NA		
715	Peracetic acid		C2H4O3	79-21-0	~10.5	NR	2	2.3	10	200
716	Perchloryl fluoride	chlorine oxyfluoride	ClO3F	7616-94-6	13.60	NR	NR	NA		
717	Perfluorobutadiene	hexafluorobutadiene	C4F6	685-63-2	9.50	NA	3	NA		
718	Perfluorocyclobutane		C4F8	115-25-3	13.5	NR	NR	NR		
719	Perfluoropropane		C3F8	76-19-7	13.38	NR	NR	NA		
720	Perfluoro-tert-butylamine		C4H2F9N	2809-92-9	10.40	NR	5	NA		
721	Petroleum ether	ligroin, VM&P naphtha, benzine		8032-32-4	~10	NA	0.9	1		
722	Phellandrene		C10H16	99-83-2	~8.2	NA	0.8	NA		
723	Phenethyl methyl ether, 2-		C9H12O	3558-60-9	~9	NA	0.6	NA		
724	Phenol	hydroxybenzene	C6H6O	108-95-2	8.51	1.1	1.2	0.9	6	120
725	Phenoxyethanol, 2-		C8H10O2	122-99-6	~8.5	10	4.5	6		
726	Phenyl chloroformate		C7H5ClO2	1885-14-9	~9	NA	1.1	NA		
727	Phenyl ethyl isobutyrate, 2-		C12H16O2	103-48-0	~9	NA	1.5	NA		
728	Phenyl propene, 2-		C9H10	98-83-9	8.35	0.4	0.4	NA	2	45
729	Phenyl-2,3-epoxypropyl ether	PGE	C9H10O2	122-60-1	~8.6	NA	0.8	NA	4	80
730	Phenylenediamine, p-		C6H8N2	106-50-3	6.87	NA	0.6	NA	3	60
731	Phenylacetaldehyde		C8H8O	122-78-1	8.80	NA	0.7	NA		
732	Phenylacetic acid		C8H8O2	103-82-2	8.26	NA	1	NA		
733	Phenylcyclohexane		C12H16	827-52-1	8.1	NA	0.4	NA		
734	Phenylethyl acetate, 1-		C10H12O2	93-92-5	~9	NA	0.7	NA		
735	Phenylethyl alcohol, 2-		C8H10O	60-12-8	~10	NA	1.2	NA		
736	Phosgene		COCl2	75-44-5	11.55	NR	NR	2.1		
737	Phosphine		PH3	7803-51-2	9.96	NA	2	1.4	10	200
738	Phthalonitrile		C8H5N2	91-15-6	9.9	NA	1.2	NA		
739	Picoline, 3-	3-methylpyridine	C6H7N	108-99-6	9.04	0.8	0.7	0.73	5	90
740	Pine oil		N/A	8002-09-3	~9.5	NA	1	NA		
741	Pinene, _-	Racemic mixture	C10H16	2437-95-8	8.07	0.48	0.34	0.43		
742	Pinene, _-		C10H16	127-91-3	8.10	0.59	0.5	0.46	2	30
743	Piperazine	1,4-diazacyclohexane	C4H10N2	110-85-0	8.72	NA	0.8	NA		
744	Piperidine	azacyclohexane	C5H11N	110-89-4	8.03	0.8	1	NA	5	90
745	Piperylene	1,3-pentadiene	C5H8	504-60-9	8.60	1	0.9	0.8	3	67
746	Prop-2-yn-1-ol	propargyl alcohol	C3H4O	107-19-7	10.50	NR	3.7	0.93	7	130
747	Propadiene	allene	C3H4	463-49-0	9.83	NA	1	NA		
748	Propan-1-ol		C3H8O	71-23-8	10.20	40	5.4	1.6	25	480
749	Propanamide		C3H7NO	79-05-0	~9.5	NA	2	NA		

Index	Chemical name	Alternative name	Formula	CAS no.	IE, eV	Response Factor (RF)			Typical MDL, 10.6 eV lamp	Typical MDL, 10.6 eV lamp
						10.0 eV	10.6 eV	11.7 eV		
750	Propane		C3H8	74-98-6	11.07	NR	NR	1.8		
751	Propane-1,2-diol	propylene glycol	C3H8O2	57-55-6	10.00	NA	3	NA	50	1000
752	Propanolamine		C3H9NO	156-87-6	~9.5	NA	1.5	NA		
753	Propargyl chloride	3-chloro-1-propyne	C3H3Cl	624-65-7	9.82	NA	2	NA		
754	Propen-1-imine, 2-		C3H5N	73311-40-7	9.65	NA	2	NA		
755	Propene	propylene	C3H6	115-07-1	9.73	2	1.4	1	7	140
756	Propiolic acid	2-propynoic acid	C3H2O2	471-25-0	10.45	NR	8	NA		
757	Propionaldehyde	propanal, propional	C3H6O	123-38-6	9.95	NA	1.7	2	8	169
758	Propionic acid		C3H6O2	79-09-4	10.44	NR	8	NA	40	800
759	Propionitrile		C3H5NO	107-12-0	11.50	NR	NR	~5		
760	Propoxy-2-propanol, 1-		C6H14O2	1569-01-3	~9.5	1.6	1.2	0.7		
761	Propyl acetate, n-		C5H10O2	109-60-4	10.04	17	3	1	13	250
762	Propyl benzene		C9H12	103-65-1	8.72	0.55	0.5	0.47		
763	Propyl benzene, 2-		C9H12	98-82-8	8.71	0.7	0.6	0.54	3	60
764	Propyl butanoate		C7H14O2	105-66-8	~9.6	2.7	1.3	0.76		
765	Propyl formate		C4H8O2	110-74-7	10.54	NR	19	1.38		
766	Propyl iodide	Iodopropane	C3H7I	107-08-4	9.26	NA	1	NA		
767	Propylamine, n-		C3H9N	107-10-8	8.5	NA	1.1	NA		
768	Propylbenzene (all isomers)	See also cumene	C9H12	74296-31-4	8.70	NA	0.5	NA		
769	Propylene carbonate		C4H6O3	108-32-7	~10.5	NR	15	2.6		
770	Propylene dinitrate		C3H6N2O6	6423-43-4	~11	NR	NR	NA		
771	Propylene glycol ethyl ether acetate	PGEEA	C7H14O3	98516-30-4	~9.6	NA	1.2	NA		
772	Propylene oxide		C3H6O	75-56-9	10.22	NR	6	1.6	35	700
773	Propyleneimine	2-methylaziridine	C3H7N	75-55-8	9.00	NA	1.4	1	7	130
774	Propylnitrate, n-		C3H7NO3	627-13-4	11.07	NR	NR	2		
775	Propyne	methylacetylene	C3H4	74-99-7	10.36	NR	4	NA		
776	Pyrazine		C4H4N2	290-37-9	9.29	NA	3	NA		
777	Pyridine		C5H5N	110-86-1	9.25	0.87	0.7	0.9	4	75
778	Pyridinol, 4-		C5H5NO	626-64-2	9.75	NA	3	NA		
779	Pyridylamine, 2-		C5H6N2	504-29-0	8.10	NA	0.8	NA	4	80
780	Pyrrole		C4H5N	109-97-7	8.02	NA	0.6	NA		
781	Pyrrolidine		C4H9N	123-75-1	8.77	20	4	1.3		
782	Pyruvaldehyde		C3H4O2	78-98-8	9.60	NA	0.7	NA		
783	Rose oxide, cis-		C10H18O	16409-43-1	~9	NA	0.8	NA		
784	Sec-amyl acetate		C7H14O2	626-38-0	~9.9	NA	5	NA		
785	Sevoflurane	1,1,1,3,3,3-hexafluoro-2-(fluoromethoxy)propane	C3H3F7O	28523-86-6	11.00	NR	NR	2		
786	Silane		SiH4	7803-62-5	11.00	NR	NR	NA		
787	Sodium fluoroacetate		C2H2O2FNa	62-74-8		NA	NR	NA		
788	Soybean oil, epoxidized, acrylate			294-415-6		NA	NV	NA		
789	Stibine	vinylbenzene	SbH3	7803-52-3	9.89	NA	1.5	NA		
790	Styrene		C8H8	100-42-5	8.40	0.52	0.45	0.5	2	50
791	Sulphur dioxide		SO2	2025884	12.32	NA	NR	NA		
792	Sulfur dichloride		Cl2S	10545-99-0	9.47	NA	2	NA		
793	Sulfur dioxide		SO2	7446-09-5	12.30	NR	NR	1.3		
794	Sulfur hexafluoride		SF6	2551-62-4	19.30	NR	NR	NA		
795	Sulfur tetrafluoride		SF4	7783-60-0	12.63	NR	NR	NA		
796	Sulphuric acid		H2SO4	7664-93-9	12.40	NA	NR	NA		

Index	Chemical name	Alternative name	Formula	CAS no.	IE, eV	Response Factor (RF)			Typical MDL, 10.6 eV lamp	Typical MDL, 10.6 eV lamp
						10.0 eV	10.6 eV	11.7 eV		
797	Sulfuryl fluoride		SO2F2	2699-79-8	13.04	NR	NR	NA		
798	Terphenyl, p-		C18H14	92-94-4	7.80	NA	0.6	NA	3	60
799	TAC	Total Aromatic Hydrocarbons			~9	0.5	0.5	NA		
800	Terpineol, _-		C10H18O	98-55-5	~9	NA	0.8	NA		
801	Terpinolene		C10H16	586-62-9	8.10	0.9	0.6	0.7	2	50
802	Terpinyl acetate, _-		C12H20O2	80-26-2	~9	NA	1.2	NA		
803	Tert-amyl methyl ether		C6H14O	994-05-8	~9	NA	0.8	NA		
804	Tert-butanol	t-butyl alcohol	C4H10O	75-65-0	10.25	2.8	1.6	1.01	15	260
805	Tert-butyl bromide	2-methyl-2-bromopropane	C4H9Br	507-19-7	9.92	1.6	0.99	0.64		
806	Tert-butyl formate		C5H10O2	762-75-4	10.52	NR	8	NA		
807	Tetrabromoethane, 1,1,2,2-		C2H2Br4	79-27-6	~10	NA	2	NA	10	200
808	Tetracarbonylnickel	nickel tetracarbonyl	NiC4O4	13463-39-3	8.28	NA	1	NA	5	100
809	Tetrachloro-1,2-difluoroethane, 1,1,2,2-		C2Cl4F2	76-12-0	11.3	NR	NR	NA		
810	Tetrachloro-1-fluoroethane, 1,1,2,2-		C2HCl4F	354-14-3	~11	NR	NR	NA		
811	Tetrachloro-2,2-difluoroethane, 1,1,1,2-		C2Cl4F2	76-11-9	~11	NR	NR	NA		
812	Tetrachloro-2-fluoroethane, 1,1,1,2-		C2HCl4F	354-11-0	~11	NR	NR	NA		
813	Tetrachloroethane, 1,1,1,2-		C2H2Cl4	630-20-6	11.10	NR	NR	0.6		
814	Tetrachloroethane, 1,1,2,2-	R-130	C2H2Cl4	79-34-5	11.10	NR	NR	0.2		
815	Tetrachloroethylene	PCE, perchloroethylene	C2Cl4	127-18-4	9.33	0.33	0.4	0.15	4	70
816	Tetrachloronaphthalene, 1,2,3,4-		C10H4Cl4	20020-02-4		NA	1	NA	5	100
817	Tetrachloropyridine, 2,3,5,6-		C5HNC14	2402-79-1	~9	NA	1	NA		
818	Tetraethyl orthosilicate	TEOS, ethyl orthosilicate, ethyl silicate	C8H20O4Si	78-10-4	9.77	3	3	1	10	200
819	Tetraethylenepentamine		C8H23N5	112-57-2		NA	0.6	NA		
820	Tetraethyllead	TEL	C8H20Pb	78-00-2	11.10	NR	NR	0.2		
821	Tetrafluoroethane, 1,1,1,2-		C2H2F4	811-97-2	~12.2	NR	NR	NR		
822	Tetrafluoroethane, 1,1,2,2-		C2H2F4	359-35-3	~12.2	NR	NR	NR		
823	Tetrafluoroethylene	R-1114	C2F4	116-14-3	10.12	NA	15	1	5	100
824	Tetrafluoromethane	carbon tetrafluoride	CF4	75-73-0	15.3	NR	NR	NR		
825	Tetrahydrofuran	THF	C4H8O	109-99-9	9.41	2.8	2.3	1.4	8	150
826	Tetrahydronaphthalene	tetralin	C10H12	119-64-2	8.46	NA	0.4	NA		
827	Tetrahydropyran		C5H10O	142-68-7	9.25	NA	3	NA		
828	Tetrahydrothiophene	thiolane	C4H8S	110-01-0	8.38	0.5	0.7	0.46		
829	Tetramethyl orthosilicate	TMOS, methyl orthosilicate, methyl silicate	C4H12O4Si	681-84-5	~10	NA	2	NA		
830	Tetramethyl succinonitrile	TMSN	C8H12N2	3333-52-6	~11	NA	1	NA	5	100
831	Thionyl chloride	Sulfurous dichloride	SOCl2	7719-09-7	~11.2	NA	NR	NA		
832	Tetramethylbenzene, 1,2,4,5-		C10H14	95-93-2	8.06	NA	0.3	NA		
833	Tetramethylbutane, 2,2,3,3-		C8H18	594-82-1	9.8	NA	1	NA		
834	Tetramethylgermane		C4H12Ge	865-52-1	9.34	NA	2	NA		
835	Tetramethylguanidine, N,N,N',N'		C5H13N3	80-70-6	8.43	NA	0.6	0.8		
836	Tetramethylsilane	TMS	C4H12Si	75-76-3	9.8	NA	2	NA		
837	Thioacetic acid		C2H4OS	507-09-5	10.00	NA	2	NA		
838	Thiocarbonyl fluoride		CSF2	420-32-6	10.45	NR	6	NA		
839	Thiocyanogen		C2S2N2	505-14-6	10.50	NR	8	NA		
840	Thioformaldehyde trimer		C3H6S3	291-21-4	9.35	NA	1.5	NA		
841	Thionyl chloride		SOCl2	7719-09-7	10.96	NR	NR	NA		

Index	Chemical name	Alternative name	Formula	CAS no.	IE, eV	Response Factor (RF)			Typical MDL, 10.6 eV lamp	Typical MDL, 10.6 eV lamp
						10.0 eV	10.6 eV	11.7 eV		
842	Thiophene		C4H4S	110-02-1	8.86	0.5	0.5	0.6		
843	Thiophosgene		CSCI2	463-71-8	9.61	NA	1	NA		
844	Thymol		C10H14O	89-83-8	~9	NA	0.7	NA		
845	Titanium-n-propoxide		C12H28O4Ti	3087-37-4	~9	NA	3	NA		
846	Toluene		C7H8	108-88-3	8.82	0.6	0.56	0.55	3	50
847	Toluene-2,4-diisocyanate	TDI	C9H6N2O2	584-84-9	8.82	NA	1.6	2	8	160
848	Toluenesulfonyl chloride, p-	tosyl chloride	C7H7SO2Cl	98-59-9	~9	NA	3	NA	15	300
849	Toluidine, o-	2-aminotoluene	C7H9N	95-53-4	7.40	NA	0.5	1	3	50
850	Tolylaldehyde, p-		C8H8O	104-87-0	9.33	NA	0.8	NA		
851	Triazine, 1,3,5-		C3H3N3	290-87-9	10.01	NA	6	NA		
852	Tributyl phosphate		C12H27O4P	126-73-8	8.91	NA	5	NA	25	500
853	Tributylamine		C12H27N	102-82-9	7.4	0.6	1.3	NA	5	100
854	Trichloro-1,1-difluoroethane, 1,2,2-		C2HCl3F2	354-21-2	11	NR	NR	NA		
855	Trichloro-1,2-difluoroethane, 1,1,2-		C2HCl3F2	354-15-4	~11	NR	NR	NA		
856	Trichloro-2,2-difluoroethane, 1,1,1-		C2HCl3F2	354-12-1	~11	NR	NR	NA		
857	Trichloro-2-fluoroethane, 1,1,2-	R 131	C2H2Cl3F	359-28-4	~11	NR	NR	1		
858	Trichlorobenzene, 1,2,4-		C6H3Cl3	120-82-1	9.04	0.5	0.6	NA	3	50
859	Trichloroethane, 1,1,1-	1,1,1-TCA, R-140	C2H3Cl3	71-55-6	11.00	NR	NR	1		
860	Trichloroethane, 1,1,2-	1,1,2-TCA, R-140a	C2H3Cl3	79-00-5	11.00	NR	NR	0.8		
861	Trichloroethylene	TCE, R-1120	C2HCl3	79-01-6	9.45	0.8	0.6	0.5	3	65
862	Trichlorofluoromethane		CCl3F	75-69-4	11.77	NR	NR	NA		
863	Trichloronitromethane	chlorpicin	CCl3NO2	76-06-2	~13	NR	NR	NA		
864	Trichlorophenoxyacetic acid, 2,4,5-		C8H5O3Cl3	93-76-5		NA	1	NA	5	100
865	Trichloropropane 1,2,3-		C3H5Cl3	96-18-4	~11	NR	NR	0.64		
866	Trichlorotrifluoroethane, 1,1,1-	R-113a	C2Cl3F3	354-58-5	11.50	NR	NR	2		
867	Trichlorotrifluoroethane, 1,1,2-	R-113	C2Cl3F3	76-13-1	11.99	NR	NR	2		
868	Triethyl phosphate		C6H15P04	78-40-0	9.79	NA	3.5	NA		
869	Triethyl phosphite		C6H15O3P	122-52-1	8.30	NA	1.5	NA		
870	Triethyl silane		C6H16Si	617-86-7	9.50	NA	2	NA		
871	Triethylamine	TEA	C6H15N	121-44-8	7.50	1.1	1.3	0.7	5	90
872	Trifluoroethane, 1,1,1-		C2H3F3	420-46-2	13.30	NA	NR	NA		
873	Triethylbenzene		C12H18	25340-18-5	~8.3	NA	0.4	NA		
874	Triethylene aluminum		C6H15Al	97-93-8	~10	NA	1	NA		
875	Trifluoroacetic acid	TFAA	C2HO2F3	76-05-1	11.46	NR	NR	NA		
876	Trifluoroethane, 1,1,2-	R-143	C2H3F3	430-66-0	12.9	NR	NR	34		
877	Trifluoroethanol, 2,2,2-		C2H3F3O	75-89-8	~13	NR	NR	34		
878	Trifluoroethene	trifluoroethylene	C2HF3	359-11-5	10.14	NA	5	NA		
879	Trifluoroethyl methyl ether, 2,2,2-	trifluoroethyl methyl ether	C3H5F3O	460-43-5	10.53	NR	10	NA		
880	Trifluoriodomethane		CF3I	2314-97-8	10.28	NA	2	NA		
881	Trifluoromethane	fluoroform	CHF3	75-46-7	13.86	NR	NR	NA		
882	Trimethoxymethane		C4H10O3	149-73-5	9.5	10	4	0.71		
883	Trimethoxyvinylsilane		C5H12O3Si	2768-02-7	~9.5	NR	1	NA		
884	Trimethylamine		C3H9N	75-50-3	7.82	0.5	0.5	0.3	3	50
885	Trimethylbenzene mixtures		C9H12	25551-13-7	8.41	0.3	0.3	0.3		
886	Trimethylbenzene, 1,3,5-	mesitylene	C9H12	108-67-8	8.39	0.5	0.4	0.4	2	30
887	Trimethylborate		C3H9BO3	121-43-7	10	NR	NR	1		

Index	Chemical name	Alternative name	Formula	CAS no.	IE, eV	Response Factor (RF)			Typical MDL, 10.6 eV lamp	Typical MDL, 10.6 eV lamp
						10.0 eV	10.6 eV	11.7 eV		
888	Trimethylcyclohexane, 1,2,4-		C9H18	2234-75-5	9.35	NA	1	NA		
889	Trimethylolpropane triacrylate		C15H20O6	15625-89-5		NA	NV	NA		
890	Trinitrotoluene 2,4,6-		C7H5N3O6	118-96-7	10.59	NA	NR	NA		
891	Trimethylene oxide		C3H6O	503-30-0	9.65	NA	1.5	NA		
892	Trimethylsilane		C3H10Si	993-07-7	9.9	NA	1	NA		
893	Trioxane	formaldehyde trimer	C3H6O3	110-88-3	10.3	NR	2	NA		
894	Tungsten hexafluoride		WF6	7783-82-6	15.53	NR	NR	NR		
895	Turpentine		C10H16	9005-90-7	~8.5	NA	0.6	NA		
896	Turpentine oil	pinenes	C10H16	8006-64-2	~8	0.5	0.6	1	3	60
897	TVOC	Total Volatile Organic Compounds			~10	1	1	1		
898	Undecane		C11H24	1120-21-4	9.56	3.1	1.1	0.4	5	100
899	Vanillin		C8H8O3	121-33-5	~9	NA	1	NA		
900	Vinyl acetate		C4H6O2	108-05-4	9.19	1.77	1.5	1	6	110
901	Vinyl bromide	bromoethene	C2H3Br	593-60-2	9.8	0.9	1.5	NA	5	100
902	Vinyl chloride	chloroethene	C2H3Cl	75-01-4	9.99	1.9	2.1	0.6	10	200
903	Vinyl ethyl ether		C4H8O	109-92-2	8.98	0.95	1	0.8		
904	Vinyl fluoride	fluoroethene	C2H3F	75-02-5	10.37	NR	2	NA		
905	Vinyl-2-pyrrolidinone, 1-	NVP	C6H9NO	88-12-0	9	3.3	4.5	2.7	5	90
906	Vinylcyclohexene	butadiene dimer	C8H12	100-40-3	8.93	0.7	0.47	0.44		
907	Vinylene carbonate		C3H2O3	872-36-6	10.08	5	3.5	1.7		
908	Vinylidene difluoride	vinylidene fluoride	C2H2F2	75-38-7	10.29	NA	5	NA		
909	Vinylsilane		C2H6Si	7291-09-0	10.1	NA	1.5	NA		
910	Water	dihydrogen monoxide	H2O	7732-18-5	12.61	NR	NR	NR		
911	Xenon		Xe	7440-63-3	12.13	NR	NR	NR		
912	Xylene mixed isomers	dimethylbenzenes	C8H10	1330-20-7	8.56	0.59	0.54	0.49	2	40
913	Xylene, m-		C8H10	108-38-3	8.56	0.53	0.5	0.46	2	50
914	Xylene, o-		C8H10	95-47-6	8.56	0.6	0.5	0.52	3	60
915	Xylene, p-		C8H10	106-42-3	8.44	0.59	0.55	0.51	3	50
916	Xylidine, all		C8H11N	1300-73-8	7.5	0.6	0.7	NA	4	70

NR: No response. The VOC's IE is too high for the lamp.

NA: Not available. Either not tested or the VOC is not volatile enough to generate a detectable vapor.

Where available: (i) an estimate of the minimum detection limit (MDL) for the A1 and AH PID sensor (ii) ionization energies were obtained from the NIST Chemistry WebBook (<http://webbook.nist.gov/chemistry/>).



Nuvair
Phone: +1.805.815.4044
Fax +1.805.486.0900
1600 Beacon Place
Oxnard, CA 93033 USA
info@nuvair.com
www.nuvair.com

Rev. 12.23