

86783

REV	DESCRIPTION	DATE	CHECKED
D	REVISED PER ECO 27955	12/12/07	ES

- NOTES:
- 1 GAS PISTON ASSEMBLY, 86784
 - 2 PART OF GAS SECTION SEAL KIT, 86796
 - 3 PART OF AIR SECTION SEAL KIT, 86797
 - 4 PART OF GAS END CAP SEAL KIT, 86798
 - 5 PARTS TO BE OXYGEN CLEANED PER HPS-4.11
 - 6 TORQUE TO 15 FT-LBS

7. THIS IS A STANDARD 4AG-25 BOOSTER WITH THE FOLLOWING MODIFICATIONS:
 -ADDED PRESSURE RELIEF VALVE (ITEM 80) TO CYCLING VALVE.
 -THE GAS SECTION TO BE CLEANED FOR OXYGEN SERVICE (SEE NOTE 5).

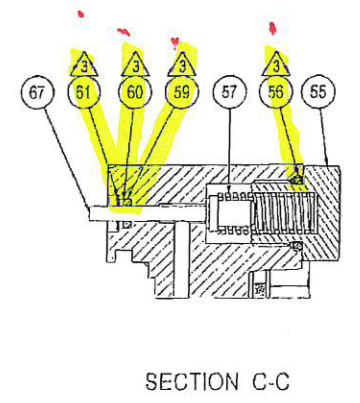
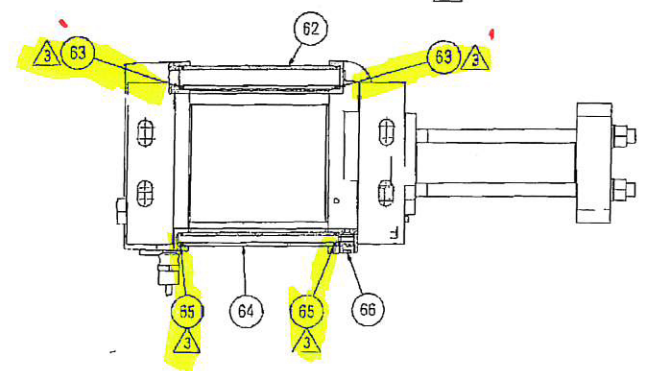
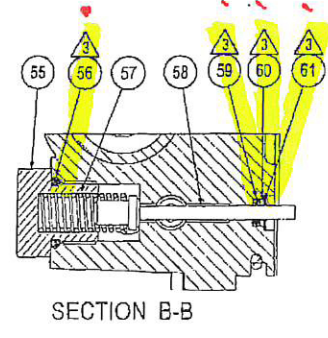
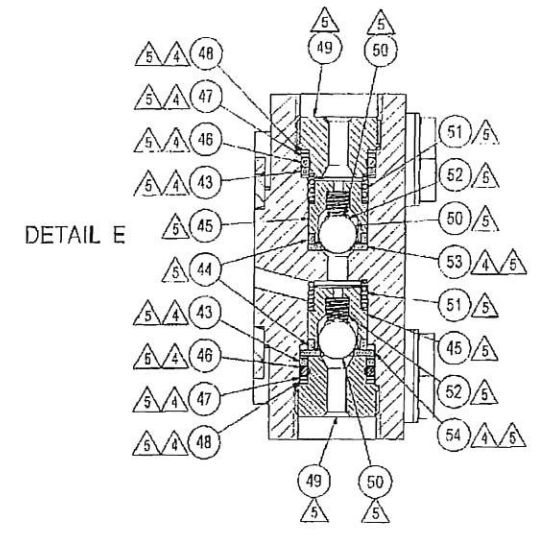
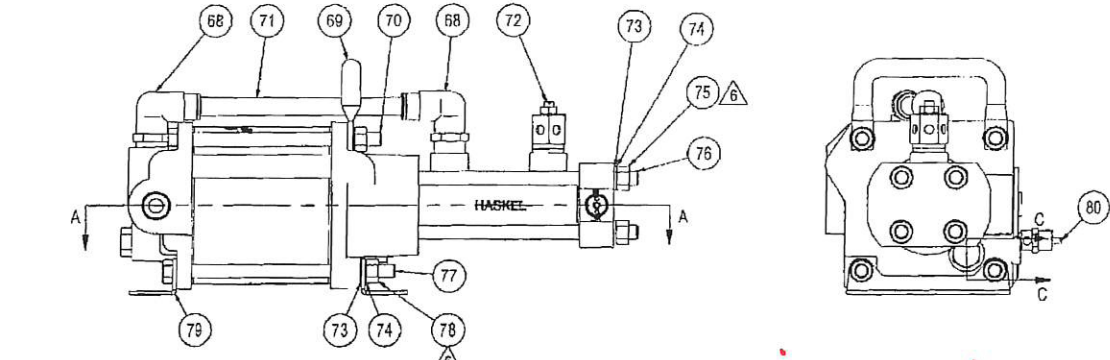
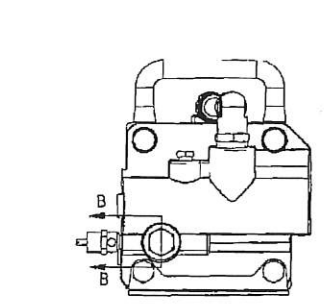
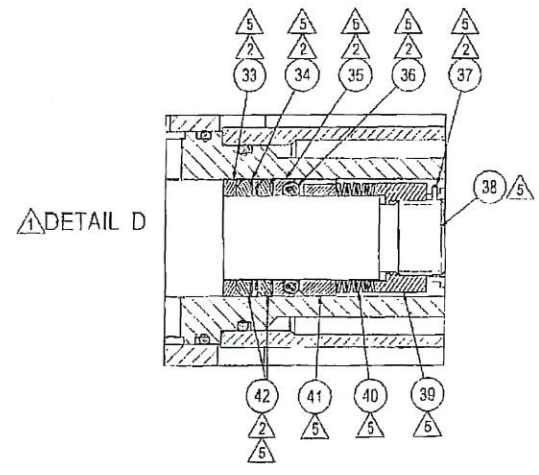
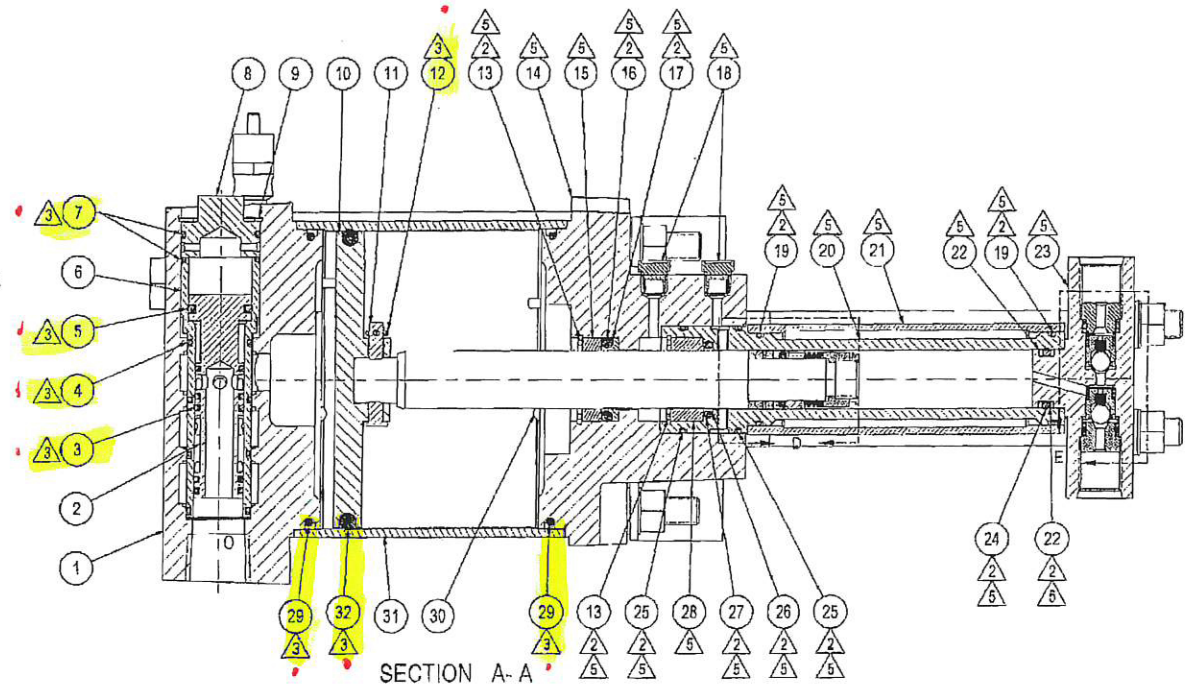

NEXT ASSY (REF ONLY)		Haskel International, Inc. Burbank, California 91502	
APPROVALS	DATE	TITLE	REV
D.MACH	08/10/06	MINI SPORT BOOSTER ASSEMBLY, MSB-9000	D
CHECKED	P.D.	SIZE	SCALE
S.Q.	11/29/06	D	N/A
CAD FILE NAME	86783	INVENTOR DRAWING	SHEET 1 OF 2

THIS DRAWING EMBODIES A CONFIDENTIAL PROPRIETARY DESIGN. ALL RIGHTS FOR REPRODUCTION, MANUFACTURING OR PATENTS ARE RESERVED BY HASKEL INTERNATIONAL, INC.